



Technical Sciences
Academy of Romania
www.jesi.astr.ro

Journal of Engineering Sciences and Innovation

Volume 10, Issue 4 / 2025, pp. 383 - 390

<http://doi.org/10.56958/jesi.2025.10.4.383>

C. Chemical Engineering, Materials Science and Engineering

Received 5 May 2025

Accepted 10 December 2025

Received in revised form 23 September 2025

Development of the experimental model for the fractionation of powerful products (derivatives) in the milling industry

SERGHEI TALPĂ, NATALIA PÎNZARU*

*Department of Physical and Engineering Sciences,
"Alecu Russo" State University of Balti, Republic of Moldova*

Abstract. The study of the specialty literature in the field of solid particle separation process showed that the use for these purposes of separation machines according to their operating properties (productivity, efficiency, safety in construction) does not meet the requirements of the milling industry. The development and introduction into the milling industry, storage and preservation of grain batches of new vibrating machines for separating solid particles contributes to the intensification of the difficult technological process mentioned above. The action through vibrations and upward air flow allows for a considerable improvement of the kinematic parameters, in this case the acceleration and frequency of the working body are increased by 5...10 times, the oscillation amplitude is reduced by 6...8 times compared to existing machines.

Keywords: vibropneumatic separator, milling, cereals, derived products, vibropneumatic separation, vibrofluidized powder product.

1. Introduction

The study of the specialized literature in the field of solid particle separation process shows that the use of separation plants for these purposes, according to its operating qualities, namely productivity, technological efficiency, their constructive safety, etc., does not always meet the advanced requirements of the milling industry, storage and preservation of grain batches. The technological efficiency and insufficient productivity of the plants used can be explained by the lack of correlation of the regimes of the mechanical action of the working body and the nature of the resistance forces from the solid particles.

The development and introduction into the milling industry, storage and preservation of grain batches of new vibrating machines for separating solid

*Correspondence address: pinzaru.natalia@yahoo.com

particles, contributes to the intensification of the difficult technological process named.

The action by vibrations allows to considerably improve the kinematic parameters, in this case the acceleration and frequency of the working body is increased by 5...10 times, the amplitude of oscillation is reduced by 6...8 times compared to existing machines.

Taking into account the important role of theory in the design of vibrating machines as well as the practical one regarding the separation process of powdery products in the grain storage, preservation and processing industries, the present work aims to reveal constructive and technological aspects of the working bodies of a vibropneumatic separator, at the same time for research purposes the problem addressed for solution also consists in the selection and use of the process and installation, which would exclude the possibility of passing foreign particles, in particular carpel particles in the flour flows, in the maximum obtaining of high quality flours.

The technological process of grinding cereal grains into derived products (groats and flour) consists of a set of processes and actions for their processing in order to obtain high-quality derived and final products.

2. Description of the technological process

The technological process of grinding cereal grains into derived products (groats and flour) consists of a set of processes and actions for their processing in order to obtain high-quality derived and final products.

The technological process at the milling enterprise is organized in three stages. One of the stages involves grinding cereal grains (for example, wheat, rye, triticale, barley, etc.) previously prepared in the preparation and cleaning section of the mill, which consists of primary grinding of grains and derived products, called the gristing process, separation of derived products by shape and size, separation of derived products in semolina machines in order to extract carpel particles and conglomerates of endosperm with carpel particles, and obtaining particles consisting only of endosperm.

The problem addressed for solution in the research process consists in selecting and using the process and installations that would exclude the possibility of passing carpel particles into the flour flows, in order to obtain maximum high-quality flours.

The regulation on the organization and management of the technological process at milling enterprises stipulates that the first-quality derived products (large, medium, small groats and dunsturs) obtained from the grinding systems - grits I, grits II, grits III, as well as the derived products obtained in the sales process are directed to the semolina machines for processing. At the same time, the derived products of the first and second quality are processed separately in the semolina machines. It should be noted that semolina machines work effectively if they ensure:

- when processing first-quality derived products:

- extraction of the sieved product without carp particles, for large groats to be within the limits of 75... 80%, for medium and small groats – 85... 90%, for dunsturi 90... 95%;
- reduction of ash content in large sieved groats to be within the limits of 30... 40%, for medium and small groats – 15... 20%, for dunsturi 10... 15%;
- when processing second-quality derived products:
 - extraction of the sieved product without carp particles, for large groats to be within the limits of 25... 35%, for medium and small groats - 40... 50%, for dunsturi 70... 80%;
 - reducing the ash content in sieved large groats to be within 60...70%, in medium and small groats - 30...40%, in dunsturi - 20...30%.

In the grinding section of the mill as semolina machines, vibro-pneumatic separators can be used, the working body of which performs complex spatial movements by applying high-frequency vibrations. At the same time, vibro-pneumatic separators can also be widely applied in other fields, for example in the food industry, in pharmaceuticals, in construction, etc.

Vibration is one of the forms of mechanical action on various powdery mixtures. In technological processes and in particular in the process of separating cereal grains and their derivatives, vibration occupies an essential place, which is also one of the most effective means of action on the product being processed.

The development and use of the equipment, the working body of which performs complex spatial movements by applying high-frequency vibrations, in various technological processes, have allowed to significantly improve the kinematic parameters, namely the increase in the acceleration of the working body, their vibration frequency, the decrease in the vibration amplitude of the working body in relation to the traditional equipment intended for separation. When the vibrations of the working body are applied to the product being processed, energy is transmitted through periodic pulses with a frequency equal to the frequency with which the working body vibrates. Regarding powdery products and in particular groats, energy is transmitted from some particles to others through their contact points. The energy obtained, in accordance with its conservation law, is consumed in overcoming and decreasing the values of the effective and true coefficients of dry friction, which occur between the particles. At the same time, the resistance of the particles is significantly reduced depending on the relative displacement, as a result, the segregation and stratification of the groats are improved.

From the above it follows that for the separation of powdery products, in particular products derived after grinding cereal grains, it is necessary to create such a regime, which corresponds to the type of powdery product subjected to processing, that is, it is necessary that the law of actuation of the working body corresponds to the nature of the resistance forces acting in the powdery product subjected to processing. For this purpose, to solve the problem addressed, it is necessary to apply the procedure of actuation of high-frequency vibrations on the powdery product. In particular, to intensify the process of separation of derived products (grain particles of various sizes, including flour particles) by quality it is necessary

to apply the actuation of high-frequency vibrations of the working body. The action of high-frequency vibrations of the working body on the by-products obtained from the grinding of cereal grains has an impulsive character, therefore, after one cycle, not much work is done, but due to the increased frequency of pulses per unit of time, a considerable production effect is achieved. The action of high-frequency vibrations of the working body contributes to the transition of the powdery product (as well as the by-products) into a pseudo-liquid state, so that the product acquires new properties and becomes more mobile, at the same time the internal and external friction coefficients are significantly reduced. With the increase in the vibration frequency of the working body, the speed of movement of the particles in the mixture also increases, intensive mixing of the particles in the mixture on the screening surface occurs. At the same time, favorable conditions are created for the effective self-sorting of particles, diverse in physical and technological properties, from the fluidized powdery product (pseudo-liquid). Large particles, with maximum density, overcoming frictional resistance, move downwards into the lower layers, and particles with relatively minimum density, under the action of high-frequency vibrations of the working element, move in the opposite direction, i.e. towards the surface of the mixture and are positioned in the upper layers.

As a result of the influence of high-frequency vibrations on the powdered material subjected to processing, the latter acquires a state similar to a viscous liquid (a fluidized layer of powdered product is created). Such a change in the rheological properties of the layer of particles (derived products) contributes to increasing the separation efficiency of vibropneumatic installations.

Therefore, high-frequency vibrations have an effective mechanical action on the powdered product subjected to processing, which allows directing the state of the powdered material in the range necessary for the implementation of the technological process.

The nature of the dynamic interaction of particles in the powdered product with the separation (dividing) surface of the working element depends on the nature of the movement of particles on the separation surface and the geometric shape of the working element. All equipment intended for separation can be classified according to the dynamic index:

- gravitational type;
- gravitational-inertial type.

Gravity-type machines include those separators in which the flat separation surface is fixed or performs rectilinear movement.

Gravity-inertial machines include all separation installations in which the screening surface moves with constant or variable acceleration in the direction.

In recent years, vibrating separation installations with a working element installed on elastic elements, which perform complex spatial movements, have been widely applied in various separation processes, and they are attributed to the gravitational-inertial type. The shape of the working element of vibrating installations is one of the basic indicators by which the classification can be carried out. Depending on the shape, the main types of vibrating installations can be highlighted, namely flat,

cylindrical, conical. Vibrating installations with a conical shape of the working element can be attributed to installations with a curvilinear surface of the working element (it can be a paraboloid or a hyperboloid of rotation).

According to the functional index, vibrating installations intended for the separation of powdery products obtained from grinding batches of cereal grains can be conventionally divided into groups. Thus, with the help of vibrating installations, powdery products (grain and flour particles) can be divided according to geometric indices, according to shape and surface properties, according to density and the complex of physico-technological properties.

Vibrating installations work as follows. The excitation force of the eccentrics, obtained from the rotational movement of the shaft of the vibrating mechanism, transmits spatial movements with high frequency and minimal amplitude to the working body. As a result of the vibration action, smaller, light and rough particles, which have low rolling properties, move to the upper layers of the product and fall into the waste accumulator. Whole, full and elastic particles with an increased specific mass move in the opposite direction, namely to the lower layers, closer to the screening surface, come into contact with the sieve surface, pass through the holes of the sieve (or sieves) and accumulate in the conical accumulator for the screened product.

At enterprises for the storage and processing of cereals, the most widespread technological process is the separation of powder mixtures according to geometric indices. For this purpose, in order to intensify this process, new models of vibrating separation installations are currently being developed, which allow increasing the productivity and quality of separation.

Figure 1 shows the construction diagram of the vibro-pneumatic separator, with a conical (or flat) shaped member placed with the tip of the cone upwards.

One of the basic design indicators is the shape of the working body, the suction chamber with a lid, the telescopic receiving connection with level fixers, the vibrating mechanism, which determine the operating efficiency of vibro-pneumatic separation installations.

One of the basic factors influencing the separation efficiency is the value of the specific load on the sieve surface, which significantly depends on the physico-mechanical properties of the product being processed. The lack of structural elements designed to change the value of the specific load on the sieve surface excludes the possibility of achieving optimal particle separation efficiency depending on the initial physico-mechanical properties of the powder product.

The vibro-pneumatic separator operates as follows. The powder product from the hopper moves into the adjustable telescopic connection 5 and through the ring 17 onto the surface of the working body 6. The telescopic shape of the receiving connection ensures its vertical movement. With the help of leveling devices 18, the distance between the ring 17 of the telescopic connection 5 and the surface of the working element 6 is adjusted, which also contributes to the product exit with retention on its surface. The respective process allows for the optimal precision

pre-setting of the output value and the thickness of the initial product layer on the surface of the working element.

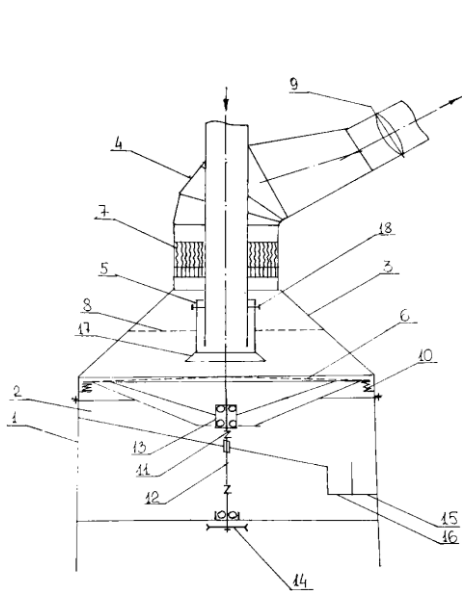

Fig. 1. Construction diagram of the vibropneumatic separator.

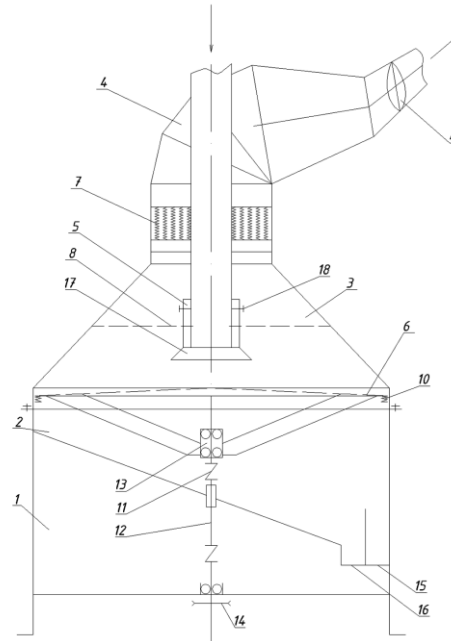

Fig. 2. Construction diagram of the vibropneumatic separator.

The ascending air flow is driven by the medium pressure pump in a flow, through the air duct, from the suction chamber and through the conical sieve 6, with a speed greater than or equal to the floating speed of the product to be processed. The ascending air flow passes through the holes of the conical sieve, through the vibro-boiling layer of the powdered product, through the perforated plate, through the corrugated plates, moving through the air duct to the air cleaning system used. The used air flow is cleaned of coarse and light particles in the discharge cyclone, and microscopic dust particles are removed in the filter-cyclone, the cleaned air flow is discharged into the environment. The technical characteristics of the vibropneumatic separator are presented in table 2.

The technological efficiency indicators of the vibro-pneumatic separator are presented in table 1. It is known that the main role of the ascending air flow in semolina machines is not to transport light particles (carp) from the product being processed, but to ensure the stratification of particles in the given product according to the hectoliter weight index. In the case of using the vibro-pneumatic separator, the main role of the ascending air flow is not only to stratify the particles

in the product being processed, but also to transport the light particles, which contain a minimum amount of endosperm, and which form the third fraction, obtained after processing the product, characterized by increased ash content. From the data in the table it is obvious that the ash content of the reject product, for all types of groats, in relation to the ash content of the sifted product, is within the limits of the requirements of the Regulation on the organization and management of the technological process at milling enterprises. Accordingly, as a result of groats processing, two fractions are obtained with a minimum ash content and a minimum content of carpal particles in the respective products. The fractions with a minimum ash content, according to the technological scheme, are directed to the appropriate grinding systems, respectively of the first and second quality. Examining the data in the table, it is obvious that the use of the vibro-pneumatic separator, characterized by relatively small dimensions, has increased productivity and with an increased yield of technological efficiency processes the derived products obtained after grinding.

Table 1 presents the technical characteristics of the vibro-pneumatic separator.

Table 1. Technological efficiency indices of the vibro-pneumatic separator

Product name	Sieve hole size,	Mass of upper weight, kg	Mass of lower weight, kg	Air flow speed, m/s	Vibration frequency (oscillation), s ⁻¹	Ash content, % of the initial product	Ash content, % of the rejected product	Ash content, % of the screened product	Ash content, % of the light product	Yield of unmelted product, %	Yield of screened product, %	Yield of light product, %	Technological efficiency E, unconf. V.	Productivity, kg/h
large grains	1,412	0,10	0,10	1,00	25	1,05	1,46	0,65	3,98	11,3	80,0	8,7	1,29	242,0
medium grains	1,093	0,10	0,10	0,60	30	0,78	1,02	0,58	2,62	8,1	84,0	7,9	1,14	223,0
small grains	0,450	0,20	0,20	0,40	35	0,65	0,93	0,51	2,23	5,3	90,0	4,7	1,15	218,0

Table 2. Technical characteristics of the vibro-pneumatic separator

Nr. d/o	Parameter name	Unit of measurement	Indices of the vibro-pneumatic separator
1.	Productivity	kg/h	
1.1.	for large groats	kg/h	2420
1.2.	for medium groats	kg/h	2230
1.3.	for small groats	kg/h	2180
2.	Groat separation efficiency	%	85...90
3.	Screening surface of the working element	m ²	0,380
4.	Oscillation frequency of the working element	s ⁻¹	25...35
5.	Amplitude of horizontal and vertical oscillations of the working element	mm	0,1...2,0
6.	Electric motor power	kW	0,27
7.	Specific volume of material used	kg/t·h	48
8.	Specific consumption capacity of electric energy	kW/ t·h	0,11
9.	<i>Dimensions: length</i>	mm	860
	width	mm	860
	height	mm	1140

3. Conclusions

1. The rationality and increased technological efficiency of vibropneumatic separation of derived products obtained after grinding is established by increasing their quality, reducing energy consumption, and reducing the specific volume of material used in the manufacture of the vibropneumatic separator in relation to existing installations.
2. To carry out the process of vibropneumatic separation of derived products, the construction of the vibropneumatic separator with a suction chamber and a working body installed on elastic elements, which perform complex spatial movements, is developed.
3. It is established that the productivity and technological efficiency of vibropneumatic separation of derived products obtained after grinding depend on the weights (eccentrics) of the upper and lower of the vibrating mechanism, the speed of the upward air flow, the dimensions of the sieve holes, the oscillation frequency of the working body, the amplitude of the horizontal and vertical oscillations of the working body.
4. It is established that the speed of the ascending air flow for the processing of large groats is equal to 1.10 m/s, for the processing of medium groats – 0.60 m/s, for the processing of small groats – 0.40 m/s.
5. Self-cleaning of the sieve of the working body is achieved, excluding the need to use complex devices for cleaning (unclogging) of the sieve holes.
6. Based on the results of research and production tests, a technological scheme of the process of grinding wheat grains into assortments using the vibropneumatic separation process of derived products is developed.

References

- [1] SU 1763052 A1 1992.09.23
- [2] RU 2303219 C1 2007.07.20
- [3] Panțuru D., Bîrsan Iu-G., *Calculul și construcția utilajelor din industria morăritului*, Ed. Tehnică, București, 1997, 201 p.
- [4] Danciu I., *Măcinarea cerealelor*, Sibiu, Editura Universității Lucian Blaga, vol. II, 2000. 298 p.
- [5] Danciu I., *Aprecieria intensității mărunțirii în industria morăritului*, Lucrările conferinței “Științe, Procese și Tehnologii agroalimentare”, Sibiu, 31 octombrie - 1 noiembrie 2002, vol. II., 450p.
- [6] Bălan I., Lupașco A., Tarlev V., *Tehnologia făinii și crupelor*, Tehnica-INFO, Chișinău, 2003. 312 p.
- [7] Мерко И.,Т. *Технология мукомольного и крупяного производства*. Москва, Агропромиздат, 1985. 288 с.
- [8] Талпэ, С.,И. *Повышение эффективности обогащения крупок при сортовых помолах пшеницы*: Дис. канд. техн. наук. Одесса, 1994. 230 с.
- [9] Talpă S., *Uscător-separator în strat vibrofluidizat și procedeu de uscare-separare*, Brevet de invenție MD 4105. C1. 2008.