



Technical Sciences
Academy of Romania
www.jesi.astr.ro

Journal of Engineering Sciences and Innovation

Volume 6, Issue 3 / 2021, pp. 289 - 306

<http://doi.org/10.56958/jesi.2021.6.3.289>

**C. Chemical Engineering, Materials Science and
Engineering**

Received 16 June 2021

Accepted 14 September 2021

Received in revised form 17 August 2021

Mössbauer studies on steel samples

ION BIBICU*

Technical Sciences Academy of Romania, Bucharest, Romania

Abstract. The paper presents the studies on the steels samples performed by Mössbauer spectroscopy. The ^{57}Fe isotope is most studied isotope by this method. The first studies were realized in the transmission geometry. Thus were studied industrial Fe-C steels, Fe-Si electrotechnical steels, the action of an organic inhibitor on the corrosion of OL37 steel and the compound formed at the Fe-Sn interface of a babbitt bearing. The following studies were concentrated on the surface studies. The development of new detectors for surface studies was accomplished. The corrosion of industrial carbon steel in diluted ammoniacal media was studied. The inhibition effect of three organic compounds on the corrosion of carbon-steel in ammoniacal solutions was determined. The corrosion of industrial carbon steel in HCl solutions was investigated. The inhibition effect of five organic compounds for samples corroded in solutions of HCl were determined. Low carbon Fe-C steel surface has been studied before and after electrolytic galvanisation.

Keywords: Mössbauer spectroscopy, Fe-C steel, Fe-Si steel, detectors for surface studies, corrosion in ammoniacal media, corrosion in HCl solutions, corrosion inhibitors, Fe-C steel electrolytic galvanization.

1. Introduction

Mössbauer spectroscopy [1] (or nuclear γ resonance) is based on the incorporation of the emitting and absorbing nuclei within a solid matrix, which enables resonant recoil free absorption and emission of γ -rays. Its importance lies in the very narrow line width of the emitting photon resulting from the relatively long lifetime of the excited nuclear state - typically of 10^{-8} s, corresponding to a natural line width of the order of 10^{-8} eV - and the consequent ability to probe the variations in nuclear energy levels resulting from any discrete changes in the chemical state and/or environment of the Mössbauer nucleus.

*Correspondence address: ionbibicu10@gmail.com

Such changes in nuclear energy levels are measured by modifying the energy of the probing γ -rays by applying a Doppler shift: a Mössbauer spectrum therefore consists of a plot of counts against applied Doppler velocity (positive and negative), the velocities corresponding to the addition and subtraction of Doppler energy shifts to the γ -ray energy. Significant recoil-free-fractions occur only for gamma energies less than 150 keV. For the collecting data it is necessary to do measurements at low temperatures as the energy of the gamma ray increases. This fact obviously means that room or high temperature Mössbauer work is possible only for a limited number of elements, (e.g. ^{57}Fe , ^{119}Sn , ^{151}Eu).

Following resonant absorption of a gamma ray, the nucleus may de-excite by emission of a gamma ray or by the process of internal conversion where an inner (K or L) shell electron is emitted. Accompanying conversion electron emission is a characteristic X-ray emitted as a result of the repopulation of the inner energy levels. Detecting the three backscattered particles, permits surface studies to be performed. The electron signal is quite high for the ^{57}Fe and ^{119}Sn isotopes. In figure 1 is presented the disintegration scheme for ^{57}Co isotope and radiation delivered by ^{57}Fe isotope after interaction with 14.4 keV resonant, incident gamma rays. The ^{57}Fe isotope is most studied isotope; over 60% from publications are dedicated to iron.

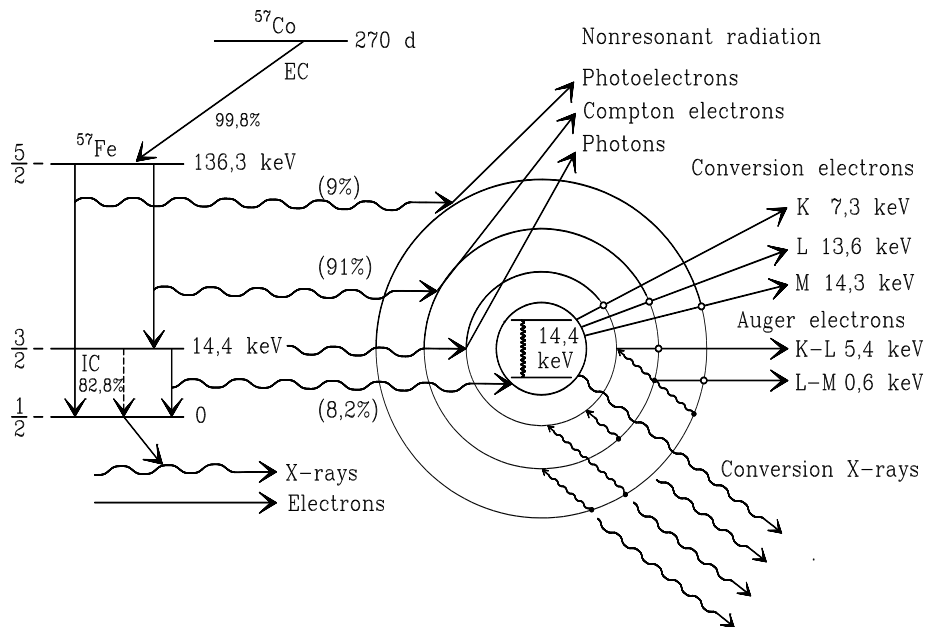

Fig. 1. Resonance electron and conversion X-ray emission associated with nuclear gamma resonance for ^{57}Fe isotope.

The normal transmission geometry investigates iron-containing samples of thickness typically < 30 microns. However, in scattering geometry surfaces,

coatings and thin films can be studied on substrates and to various depths through the detection of three backscattered radiations. The maximum depths studied with ^{57}Fe isotopes are: 250 nanometers by 7.3 keV conversion electrons, (Conversion Electron Mössbauer Spectroscopy: CEMS) 20 microns by 6.4 keV X-rays, (X-ray Mössbauer spectroscopy: XMS) 30 microns by 14.4 keV gamma-rays (Gamma-ray Mössbauer spectroscopy GMS). By means of the conversion electron detection, Mossbauer spectroscopy became one of the methods for surface characterization.

Mössbauer spectroscopy is studying the hyperfine interactions via the following hyperfine parameters:

a) Isomer shift (σ) arises because the nuclear energy levels are sensitive to changes in electron density at the nucleus, from differences in local topology as well as in valence state of the Mössbauer isotope.

b) Electric quadrupole splitting (ΔE_Q) arises for any nucleus with nuclear spin quantum number I greater than $1/2$ and which, therefore, possess a non-spherical charge distribution. The magnitude of this non-sphericity is given by the nuclear quadrupole moment Q .

c) Magnetic hyperfine splitting. This will occur if there is a magnetic field at the nucleus. The hyperfine magnetic field can originate either within the atom itself or as a result of placing the compound in an externally applied magnetic field. Any interaction between the nuclear magnetic dipole moment and hyperfine magnetic field at the nucleus lifts the degeneracy of the magnetic sublevels and gives rise to $2I + 1$ levels. For iron, where $I = 1/2$ and $3/2$, this results to a characteristic 6-line pattern. Separation between the peaks in the spectrum is proportional to the magnetic field at the nucleus. Measuring the magnetic hyperfine splitting permits to gain extremely useful information about the magnetic properties of the compounds investigated.

All mentioned hyperfine interactions can occur simultaneously. In magnetically ordered compounds, with a non-vanishing electric field gradient, the shape of the spectrum depends on the relative strengths of the magnetic dipole and the electric quadrupole interaction. A detailed analysis of the chemical state of Mössbauer atoms, within the material: valence state, chemical compound, it is possible to realize from values of hyperfine interactions. The spectrum shape is a feature for a given chemical compound.

d) Recoil free fraction (f – factor). A necessary condition for absorption to occur is that the emitting and absorbing atoms form part of a rigid lattice, such that recoil energy associated with emission and absorption of the γ -quantum is taken by the lattice as a whole. The probability of such an event depends on the size of the recoil energy and the spectrum of quantified vibration energy levels that describe the motion of the lattice. The intensity of the Mössbauer effect is thus determined by recoil free fraction or f factor.

From values of hyperfine interactions and f -factor it is possible to derive the phase analysis and the site population for the various sites in a specific phase. Sometimes these hyperfine interactions might be time-dependent (diffusion, superparamagnetism and life-time). Additionally, the measuring efficiency might

depend on the material and its temperature. Mössbauer spectroscopy is one of the numerous methods for the analysis of the phase composition and the microstructure of materials. The ^{57}Fe is the most studied isotope followed by ^{119}Sn and ^{151}Eu .

Mössbauer spectroscopy gains its sensitivity and selectivity from two factors: the penetration depth determined by the applied methodology and the isotopic specificity. Surface/interface information can be easily extracted from thin film or multilayer spectra by local character and the site specificity of Mössbauer spectroscopy, if the surface/interface atom contribution is meaningful.

Mössbauer spectroscopy [2-4] has as one of its most important features the ability to simultaneously undertake bulk and surface analyses. It is a non-destructive technique that can be applied *in situ* to investigate surface of varying thickness from thin films to coatings without the need to remove them from their substrate. On the other, it suffers from a lack of sensitivity and for the very thin surfaces and interfaces take too long acquisition times. With the growing interest in nanomaterials, catalysis and corrosion the surface Mössbauer technique will be more widely used.

The paper presents the studies on the steels samples, obtained from industrial units, performed by Mössbauer spectroscopy. The first studies were realized in the transmission geometry. Thus were studied industrial Fe-C steels, Fe-Si electrotechnical steels, the action of an organic inhibitor on the corrosion of OL37 steel and the compound formed at the Fe-Sn interface of a babbit bearing. The following studies were concentrated on the surface studies. The development of new detectors for surface studies was accomplished. The corrosion of industrial carbon steel in diluted ammoniacal media was studied. The inhibition effect of three organic compounds on the corrosion of carbon-steel in ammoniacal solutions was determined. The corrosion of industrial carbon steel in HCl solutions was investigated. The inhibition effect of five organic compounds for samples corroded in solutions of HCl were evaluated. Low carbon Fe-C steel surface has been studied before and after electrolytic galvanisation.

2. Studies in transmission geometry

The first studies were realized in the normal transmission geometry which investigates iron-containing samples of thickness typically < 30 microns.

2.1. Fe-C steels

In the studies of Fe-C steels the scope was to develop a study method for steel, method useful for a physical metalurgy laboratory and to determine hyperfine parameters for samples delivered by Hunedoara steel plant [5]. Were analyzed the following steel samples in the concentration range of 0,10-0,60 w%C: OLC-10 with 0.07 and 0.11 w%C, OLC-15 with 0.15 w%C, OLC-25 with 0.25 w%C, OLC-35 with 0.37 w%C, OLC-45 with 0.47 w%C, OLC-55 with 0.56 w%C OLC-60 with 0.59 w%C. The measurements were performed at room temperature. The

Mössbauer spectra were analysed with a computer fitting program for three magnetic sublattices. The isomer shift was measured compared to the source. The following hyperfine parameters were determined: magnetic hyperfine splitting, electric quadrupole splitting and isomer shift. The values of these parameters are given in the Table 1 for all investigated samples.

Mössbauer spectrum of the sample OLC-10 with 0.07 w%C is best fitted with a single magnetic lattice (single sextet) with parameters very close to pure metallic Fe (≈ 331 KOe magnetic field). In the sample OLC-10 with 0.11 w%C we found a new sextet with lower magnetic field ≈ 317 KOe. The second sextet is present in all samples with higher C concentration. In the sample with 0.37 w%C concentration and higher is present a new sextet, the third, with magnetic field ≈ 160 KOe.

Table 1
The values of determined hyperfine parameters

Steel	Isomer shifts [mm/s]			Quadrupole Splitting [mm/s]			Hyperfine Fields [KOe]		
	1	2	3	1	2	3	1	2	3
Sublattice at % C									
Pure metallic Fe	0.226 ± 0.01			0			331.1 ± 0.03		
OLC-10 0.07	-0.22 ± 0.03	-	-	0.00 ± 0.03	-	-	326.4 ± 0.9	-	-
0.11	-0.23 ± 0.03	0.03 ± 0.03	-	0.04 ± 0.03	0.01 ± 0.03	-	327.8 ± 0.9	315.9 ± 1.1	-
OLC-15 0.15	-0.23 ± 0.03	-0.21 ± 0.03	-	0.00 ± 0.03	0.03 ± 0.03	-	328.8 ± 0.9	316.7 ± 2.5	-
OLC-25 0.25	-0.25 ± 0.03	-0.21 ± 0.03	-	0.02 ± 0.03	0.00 ± 0.03	-	331.4 ± 0.9	320.0 ± 0.9	-
OLC-35 0.37	-0.25 ± 0.03	-0.23 ± 0.03	0.23 ± 0.03	0.00 ± 0.03	0.02 ± 0.03	0.58 ± 0.06	333.0 ± 0.3	321.0 ± 1.1	179.5 ± 2.7
OLC-45 0.47	-0.24 ± 0.03	-0.22 ± 0.03	0.43 ± 0.05	0.00 ± 0.03	0.03 ± 0.03	0.62 ± 0.04	331.0 ± 0.4	320.4 ± 0.9	155.7 ± 4.1
OLC-55 0.56	-0.24 ± 0.03	-0.22 ± 0.03	0.41 ± 0.05	0.02 ± 0.03	0.00 ± 0.04	0.62 ± 0.09	329.3 ± 0.9	314.6 ± 5.8	156.9 ± 4.0
OLC-60 0.59	-0.23 ± 0.03	-0.20 ± 0.03	0.45 ± 0.03	0.00 ± 0.03	0.00 ± 0.03	0.60 ± 0.03	331.5 ± 0.9	319.0 ± 1.4	156.5 ± 2.2

The three observed sublattices can be attributed as follows: the sextet with the highest value of the magnetic hyperfine field, noted sublattice 1, can be attributed to Fe atoms with C atoms neighbouring of order 3 and 4 and Fe atoms not affected by the presence of C atoms; sublattice noted 2 corresponds to Fe atoms with C atoms neighbouring of order 1 and 2; sublattice noted 3, with the lowest value of the magnetic hyperfine field represents a new compound: Fe₃C cementite.

Magnetic hyperfine field for the sublattice 2 does not depend on C concentration, showing that C atoms filled uniformly interstitial positions. The high value of the quadrupole splitting for cementite attested a significant distortion of its network. After the cementite appearance, the C atoms do not enter in sublattice 2, C atoms

enter preferably in cementite. Also magnetic hyperfine field for the cementite does not depend on C concentration.

2.2. Fe-Si electrotechnical steels

The use of Fe-Si alloys in electrotechnical industry as magnetic material has encouraged the investigations of this alloy for getting a better understanding of their physical properties. In our study [6] we proposed to use Mössbauer spectroscopy as a standard method of investigation in order to determine the magnetic fields for Fe-Si electrotechnical steels with low Si concentration (< 7.92 % Si). At the same time we discussed the results by means of the model of the variation of the spin polarization of the 4s-like electrons with distance from the iron atom.

Fe-Si samples with Si concentration in the range 5.77 – 7.92% Si were prepared and measured as Fe-C steel samples, at room temperature. Also the experimental data were analysed in the same manner. The values of hyperfine magnetic field and isomer shifts for all investigated samples are summarized in the Table 2.

Table 2
The values of hyperfine field and isomer shift for Fe-Si electrotechnical steels at room temperature

Fe-Si Steel	Hyperfine Fields H_n [kOe]			Isomer shifts [mm/s]		
	1	2	3	1	2	3
Sublattice at % Si						
5.77	333.9	309.0	279.5	-0.21	-0.17	-0.15
6.13	334.3	309.6	285.2	-0.19	-0.16	-0.09
6.19	335.0	310.6	276.8	-0.20	-0.15	-0.06
6.38	333.4	308.7	274.7	-0.19	-0.15	-0.05
6.50	332.3	307.9	290.9	-0.19	-0.16	-0.06
6.58	335.1	310.4	275.5	-0.20	-0.16	-0.10
6.85	334.8	310.0	273.9	-0.18	-0.14	-0.09
7.08	333.9	309.2	275.1	-0.19	-0.14	-0.07
7.92	334.8	319.3	282.4	-0.18	-0.15	-0.01

The error for isomer is ± 0.02 mm/s and for hyperfine field is ± 1.4 kOe

From obtained data one can conclude the existence of three magnetic sublattices with values of the hyperfine magnetic fields of $H_1 \approx 334$ kOe, $H_2 \approx 310$ kOe and $H_3 \approx 279$ kOe. These values do not depend on the Si content. The three observed sublattices can be attributed as follows: the sextet with the highest value of the magnetic hyperfine field, noted sublattice 1, can be attributed to Fe atoms with Si atoms neighbouring of order 4 and 5; sublattice noted 2 corresponds to Fe atoms which in 1 shell have an iron atom replaced by a Si atom; sublattice noted 3 corresponds to Fe atoms which in 2 shell have two iron atoms replaced Si atoms.

Our results confirmed the hypothesis of the polarization of conduction electrons caused by the spin and charge perturbation of the 4s band of iron due to the interaction with the excess charge of the Si impurity atoms. The independence of the isomer shifts on silicon content may be explained by the screening of the excess charge of Si atoms by 4s-like electrons.

2.3. The corrosion of Fe-C in the presence of an organic inhibitor

The steel corrosion and its prevention is very important for metallurgical industry. We applied the Mössbauer spectroscopy to investigate the action of an organic inhibitor on the corrosion of steel [7].

The samples investigated were made from laminated sheet of OL 37 steel. The concentration of carbon of this steel is less than 0.2%. Mössbauer spectra were taken for the following samples at room temperature: uncorroded (sample 1), immersed in a 10% H₂SO₄ aqueous solution for 20 minutes (sample 2), immersed in the same solution for 2.5 hours to which dibenzil sulfoxide inhibitor was added (sample 3).

The samples were measured at room temperature and the experimental data were analysed in the same manner as Fe-C and Fe-Si steels. The values of hyperfine magnetic field, quadrupole splitting and isomer shifts for investigated samples are summarized in the Table 3.

Table 3
The values of hyperfine field, quadrupole splitting and isomer shift at room temperature inhibitor

Sublattice	Isomer shifts [mm/s]				Quadrupole Splitting [mm/s]				Hyperfine Fields [kOe]			
	1	2	3	4	1	2	3	4	1	2	3	4
Sample 1	-0.21	-0.17	-0.03	-	0.00	-0.01	0.00	-	332.4	305.5	195.2	-
Sample 2	-0.17	-0.13	-0.07	-0.07	-0.01	-0.02	-0.05	-0.02	328.5	324.0	194.6	454.5
Sample 3	-0.06	-0.03	0.10	-	0.07	0.08	0.09	-	329.8	316.6	174.4	-

The errors are: ± 0.02 mm/s for isomer shift; ± 0.05 mm/s for quadrupole splitting; ± 1.4 kOe for hyperfine field of the sublattices 1, 2, 3; ± 2.9 kOe for hyperfine field of the sublattice 4.

Three sextets were observed in the spectra of samples 1 and 3 with the parameters similar to precedent Fe-C samples. The spectrum of the sample 2 (exposed to corrosion without inhibitor) exhibits four hyperfine sextets; the parameters of three of them are similar to those of the sample 1, while the fourth sextet corresponds to a superficial film of δ -FeOOH. The fourth sextet does not appear in the spectrum of the sample 3. In this way, the lack of iron product in the superficial layer formed in the presence of the organic inhibitor is proved. The Mössbauer spectrum and ellipsometric measurements suggested that organic inhibitor acts by forming an adsorbed layer.

Mössbauer spectrum show that in the absence of the inhibitor, corrosion progresses rather normally than parallel to the sample surface. A fraction of the iron atoms leaves the metal passing into solution, whereas another fraction forms the

superficial product. The iron atoms of the 1st and 3rd sublattices are the most affected by this process. When inhibitor is added to the solution the process is the same, until the inhibitor film covers the metal surface.

2.4. The study of the interface from a babbit bearing

The babbit bearings are very important parts of the rolling mills used to produce different metallic plates. Usually babbit bearings are from steel body on which are applied a friction material. The composition and the structure of interface from body and friction material are important for a long life of the bearing.

Mössbauer spectra were taken for the following samples: Fe metallic, sample from bearing body (sample 1), sample from interface (sample 2). Sample from interface was measured at room temperature (sample 2) and at 77K (sample 2*). The experimental data were analysed in the same manner as Fe-C. The values of hyperfine magnetic field, quadrupole splitting and isomer shifts for investigated samples are summarized in the Table 4.

Table 4
The values of the Mössbauer parameters

Sublattice	Isomer shifts [mm/s]				Quadrupole Splitting [mm/s]				Hyperfine Fields [KOe]			
	1	2	3	4	1	2	3	4	1	2	3	4
Fe	0.00	-	-	-	0.00	-	-	-	331	-	-	-
Sample 1	0.00	0.00	-	-	0.00	0.00	-	-	332	323		
Sample 2	0.00	0.00	0.56	-	0.00	0.01	-	-	334	326		
Sample 2*	0.16	0.15	-	0.70	0.02	0.02	-	0.01	342	326	-	152
Error	0.02				0.03				3			

The spectrum of the sample 1 was best fitted with 2 sextets and a single line. The sextet with the highest value of the magnetic hyperfine field, noted sublattice 1, can be attributed to Fe atoms with C atoms neighbouring of order 3 and 4 and Fe atoms not affected by the presence of C atoms; sublattice noted 2 corresponds to Fe atoms with C atoms neighbouring of order 1 and 2. The single line shows the presence of a compound without magnetic ordering. At 77K the sublattices 1 and 2 are presently, single line is absent and a new sextet (sublattice 4) is appearing. Its parameters are characteristic for FeSn₂ compound at 77K.

Our measurements showed that supermagnetic FeSn₂ has formed at the interface region of the babbit bearing with a maximum 1000Å particle dimension.

3. Detectors for surface studies

Mainly, the following studies were concentrated on the surface studies owing to their importance and elimination of complicated sample preparation. The development of new detectors for surface studies was accomplished.

The following proportional counters for conversion Mössbauer spectroscopy have been developed: detectors for conversion electron and transmission Mössbauer spectroscopy [9], [10]; detector for conversion X-ray and transmission Mössbauer spectroscopy (CXMS) [11], [12], [13]; detector assembly for simultaneous conversion electron, conversion X-ray and transmission Mössbauer spectroscopy [10]; versatile flow-gas proportional counter for surface Mössbauer spectroscopy [14]. All detectors are flow-gas type and operating at room temperature. Their construction permits for all detectors to realize simultaneous transmission and conversion measurements. The background due to photoelectrons is minimised by using low-Z materials as much as possible. The sample holder allows an easy manipulation of a sample, outside the detector and sample can always be repositioned in a reproducible manner with respect to the detector body. We have used for detectors an economical shielding which consists of a combination of lead, copper and steel disks. To destroy the characteristic radiation, alternate mounting of the lead, copper and steel disks were used. A plexiglas filter is placed in front of the shielding in order to absorb unfavourable KX-rays from the source. We constructed flow-gas proportional counters for resonance electrons using two variants to dispose the anode wire: a circle around the sample [9], [10] and lines in front of the sample [14]. The second variant has better performance. The test measurements argue the versatility of these counters for the comparative study of surface and bulk properties of Mössbauer samples.

The proportional detector for conversion X-ray and transmission Mössbauer spectroscopy [11], [12], [13] has toroidal shape of the space detection and a lower efficiency for the 14.4 keV r-rays. The resonance effect can be optimised by a proper choice of the anode voltage and the filter. The design is simpler than those previously reported for similar devices.

The detector assembly for simultaneous conversion electron, conversion X-ray and transmission Mössbauer spectroscopy [10] consists mainly of two gas-flow proportional counters combined together. The sample to be studied is mounted inside the smaller counter designed for detecting electrons backscattered from the sample. The larger counter is used to detect conversion x-rays that come from the sample and pass through the electron counter. This assembly has a low efficiency for backscattered 14.4 keV y-rays. The counter design and operation are simpler than previously reported.

The versatile flow-gas proportional counter for surface Mössbauer spectroscopy [14] represent a synthesis of our experience in the development of flow-gas proportional detectors for surface studies. The main improvements obtained by new design are: the height of the detection volume can be changed in large limits from 1 to 38 mm, the detection volume can be choose symmetrical or not in respect with anode plan, the anode changing is easily and different anode configuration can be used. By changing the volume detection and flow gas it is possible to make measurements by electron, X-ray detection or gamma-ray detection. The diagram of this detector is present in figure 1.

The detectors were inserted into a Mössbauer spectrometer. The spectrometric chain has been supplemented with additional modules such as to allow simultaneous recording of spectra. To test the performance of the counters, Mössbauer measurements were carried on reference samples as: a 25 μm thick stainless steel sample (type 310), a rhodium foil 30% enriched in ^{57}Fe , β -tin foil. The parameters of Mössbauer spectra have been calculated using a specialized, computer-fitting program, which assumes Lorentzian line resonances.

4. Studies in backscattering geometry

Many studies were carried by conversion electron Mössbauer spectroscopy (CEMS). So were investigated, for example: the effects induced, mainly in surface, by pulsed radio frequency annealing; the structural and magnetic properties of different films; superficial characterization of α -iron oxides obtained by hydrothermal synthesis; nanocrystallization process; corrosion processes; the surface phase composition of bulk and thin films samples of SnSe_2 , etc. Some of them, effected on steel samples are shortly described below.

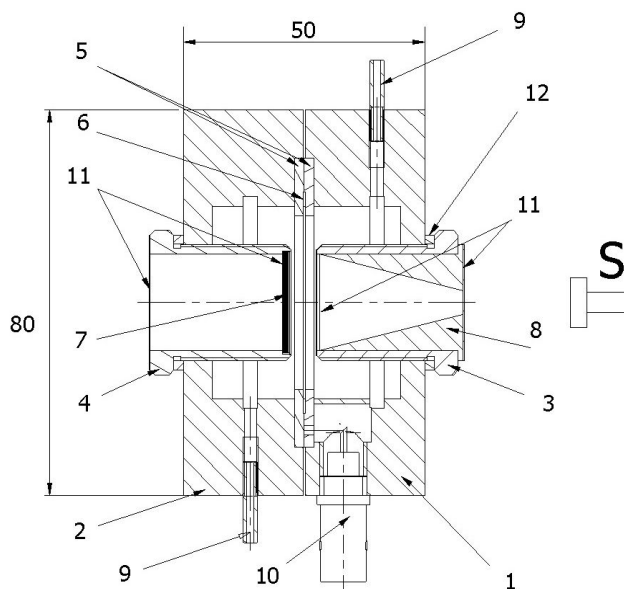

Fig. 1 The cross section of the versatile flow-gas proportional counter: 1 and 2 main parts of the counter, 3 input piece, 4 sample holder, 5 teflon insulator, 6 anodic ring, 7 sample, 8 collimator, 9 gas connection, 10 high voltage connector, 11 mylar windows, 12 tightness piece, S Mössbauer source.

4.1 The corrosion of carbon steel in diluted ammoniacal media

Recent researches, have showed that the industrial and residual waters containing ammonia/ammonium have a negative impact on the environment leading to pipe

corrosion in the cooling waters systems, especially in the ammonium fertilizer industry.

The samples were corroded in a standard electrolytic cell with the followings diluted ammonia/ammonium solutions: diluted ammoniac solutions with NH_3 concentration of 10^{-1} M, 10^{-2} M, 10^{-3} M and 10^{-4} M [15]; ammonium salts solutions: 0.1M NH_4Cl , 0.1M NH_4Cl with 0.05M NH_4NO_3 , [16]; solution 10^{-3} M NH_3 with $5 \cdot 10^{-3}$ M NH_4Cl [17]. The CEMS spectrum of the sample corroded in solution with 10^{-3} NH_3 concentration is shown in figure 2. The best fit of the CEMS spectrum for the corroded sample uses an addition Fe^{3+} paramagnetic doublet respectively two paramagnetic doublets to the sextet. The parameters of the sextet are almost identical to those of the non-corroded sample.

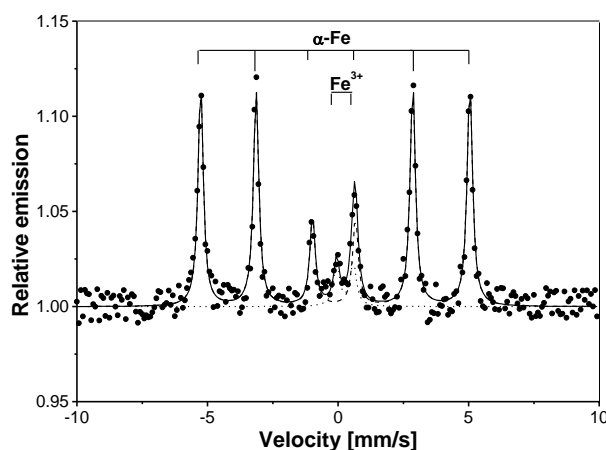

Fig. 2. CEMS spectrum of a Fe-C steel sample corroded in a solution with 10^{-3} NH_3 concentration (● data; — fit).

The slight changes of the hyperfine magnetic values and isomer shifts suggest that in the process of corrosion there may be a certain preference for the positions of iron, which are not close to the atoms of the alloying elements. The preferential orientation of the magnetic moments in the sample plane continues to exist even after the corrosion of the samples. The main difference between the corroded sample sextets and the non-corroded sextets consists in the decrease of the intensity lines corresponding to $\alpha\text{-Fe}$. This demonstrates, once again, the presence of a superficial layer on the corroded samples surface. There is a process of inhibition of carbon-steel corrosion in the ammoniac solutions, which is evidenced by the increase of the superficial layer when NH_3 concentration decreases. The parameters of the doublets show the presence of Fe^{3+} and are similar to those shown by amorphous Fe^{3+} oxyhydroxides, superparamagnetic $\alpha\text{-FeOOH}$ and/or $\gamma\text{-FeOOH}$ and $\text{Fe}(\text{OH})_3$. Small relative area of the doublet, as well as its parameters shows the initial stage of the corrosion. At this stage we believe that the main product of

the corrosion in NH_3 solution is an amorphous Fe^{3+} oxyhydroxide with a non-stoichiometric composition. Mössbauer data showed that for the samples corroded in ammonium salts solutions the main corrosion product is a mixture of Fe(III) ferrihydrate and FeOOH (alpha and/or gamma). The introduction of NO_3^- anion in a solution of 0.1M NH_4Cl in $\text{NO}_3^-/\text{Cl}^- = 1/2$ ratio has an inhibiting effect by decreasing the expansion rate of generalized corrosion of carbon steel. This effect is demonstrated by the increase of the sextet lines intensity and the dramatic decrease of the Fe^{3+} paramagnetic doublet.

Numerous advanced treatments using organic compounds have been proposed in order to improve the corrosion protection. The inhibition effect of three organic compounds: 2-mercapto-benzothiazol (MBT) [18], N-ciclohexil-benzothiazole-sulphenamida (NCBSA) [19] and etilentiouree (ETU) [20] on the corrosion of carbon-steel in diluted ammonia /ammonium solutions at room temperature were studied. The CEMS spectrum of a corroded sample in a solution with 10^{-3} HN_3 concentration with 250 ppm NCBSA inhibitor is presented in figure 3. The similar spectra are obtained for MBT and ETU inhibitors. In these spectra there is no evidence for any iron corrosion product at the surface.

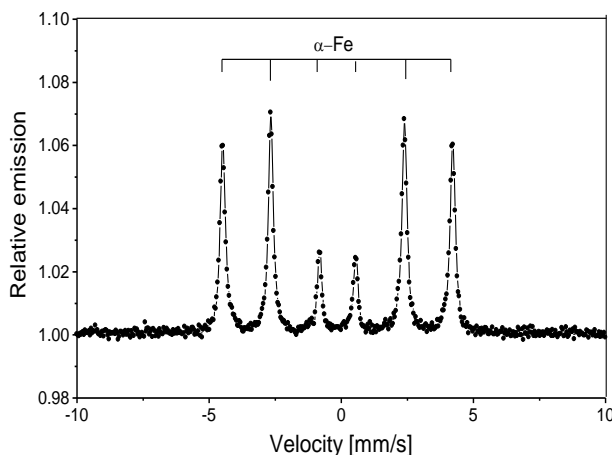

Fig. 3. CEMS spectrum of a corroded sample in a solution with 10^{-3} HN_3 concentration with NCBSA inhibitor (● data; — fit; --- $\alpha\text{-Fe}$).

In the spectrum there is no evidence for any iron corrosion product at the surface. A relative decrease of the $\alpha\text{-Fe}$ line intensities as compared with the sextet obtained in the corrosion process without inhibitor indicated formation of a superficial layer. Also the increased magnetic anisotropy of the CEMS spectra in the presence of the inhibitors confirms the action of the inhibitor. Mössbauer spectroscopy proved together other methods the inhibition action by a formation of a superficial film without iron compounds on the surface of the corroded samples. This layer is interpreted in terms of the formation of complexes between inhibitors and the metal cations present in the carbon-steel structure. The data indicate a good absorbability of inhibitor on the metal surface.

4. 2 The corrosion of carbon steel in HCl solutions

Acid solutions are widely used in industry, the most important fields of application being acid pickling, industrial cleaning, acid decaling, oil-well acid in oil recovery and the petrochemical processes. One of the most aggressive media for the ferric materials is the aqueous solution of hydrochloric acid. To understand and to reduce the corrosive attack on metallic materials is an important task from economical point of view.

The samples were immersed in a closed system for 3h in solutions of 1 M HCl [21] or 2 M HCl [2], [23]. The CEMS spectrum of the sample corroded in 1 M HCl solution is shown in figure 4. The best fit of the CEMS spectrum uses addition of two Fe^{3+} paramagnetic doublets to the sextet. The parameters of the doublets show the presence of Fe^{3+} and are similar to those shown by nonstoichiometric Fe^{3+} oxyhydroxides. The superficial layer consists of a mixture of α , β and γ - FeOOH . The superficial layer is thicker for sample corroded in HCl solutions than those corroded in ammonia media. In the 2 M HCl solution the corrosion layer is thicker than the layer formed in the corrosion in 1 M HCl solution and with the same superficial compounds.

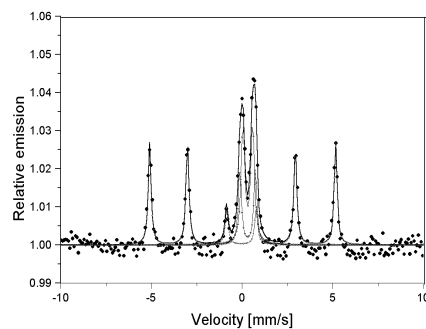

Fig. 4. CEMS spectrum of a corroded sample in a 1 HCl solution (• data; — fit).

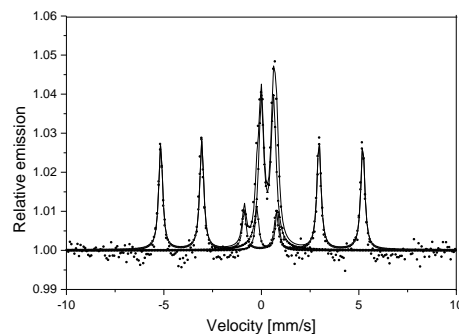

Fig. 5 CEMS spectrum of a corroded sample in a 1M HCl solution with APM inhibitor (• data; — fit)

The importance of inhibition is much greater in solutions of hydrochloric acid since iron and its alloys are the most exposed materials both in industrial and other media. The inhibition effect of five organic compounds for samples corroded in solutions of HCl solutions were investigated: ammonium polymolybdate (APM) [21], figure 5, n-acetyl p-aminobenzene sulfonamide (APAS) [22], N-(2hydroxybenzilidene) thiosemicarbazide (HBTC) [23], Bis (benzothiazolyl) disulphide (BTD) [24], and 2-(cyclohexylaminomercapto) benzothiazole (CMB) [25]. All tested inhibitors operate in the same manner. The process of corrosion is considerable slowed in the inhibitor presence and a superficial compound of Fe^{3+} without a magnetic arrangement is formed. The diminution of the corrosion process is indicates by the increased magnetic anisotropy of the CEMS spectra in the presence of the inhibitors. This means that the depth of the corroded surface layer is lower in the inhibitor presence or corrosion velocity diminished.

By estimating the relative area of the superficial compound and the increased magnetic anisotropy of the CEMS spectra in the presence of the inhibitors, results that the compound has a smaller thickness or, in extreme case is similar with the layer formed in the corrosion process without inhibitor. The Mössbauer parameters of the compound in this case do not differ too large from the ones found for the corroded sample in the solution without inhibitor. The new parameters can be ascribed to nonstoichiometric compounds as well as to low crystallinity, e.g. ferrihydrates. It is known that ferryhydrite is a precursor of other ordered iron oxyhydroxides. We consider that the organic inhibitors used in HCl solutions act as an incipient “rust transformer” and favours the formation of a “superficial closed layer”. These inhibitors transform some constituents of rust into corrosion inhibiting oxide phases. For the corroded samples in a solution of 2M HCl, the inhibition process is the same as in 1M HCl solutions.

4. 3 Characterization of surface and interface of a Fe-C steel under electrolytic galvanisation

The use of Zn coatings is one of the most important anticorrosive protections of steels and has a long history. There are permanent efforts to optimize the existing processes such as the study of electrodeposition conditions, the effects of additives to electrolyte solutions, the effect of organic impurities, etc.

We study the surfaces and interfaces of low carbon Fe-C steel under electrolytic galvanisation; type of deposition: weakly acid electroplating [26]. Low carbon Fe-C steel surface has been investigated before and after electrolytic galvanisation using mainly nondestructive physical techniques. The obtained information is important from both scientific and technological point of view.

The samples were obtained from hot laminated roll and its surfaces were treated to remove all grease or oily contaminants. The electrodeposition of Zn was performed in the standard cell of 267 ml capacity. Mössbauer effect measurements were performed in two geometries: transmission (TMS) and backscattering with a conventional constant-acceleration spectrometer. Lorentzian line shapes were

considered to fit the recorded Mössbauer spectra. A sample from surface of the initial sample was obtained by scrapping. Information about samples surfaces was found in backscattering geometry by detecting conversion electrons (CEMS) and conversion X-rays (CXMS).

The surface measurements on initial sample by conversion electrons prove a marked corrosion: a coating with a considerable thickness and a complex composition. Hematite is a main compound of outermost layer. Its Mössbauer parameters are practically the same with those given in literature. The second compound in outermost layer is magnetite with a normal stoichiometry as in different references. In outermost layer there is also goethite. Mössbauer parameters for goethite have a great dispersion. The reduced hyperfine magnetic field of goethite compared with well-crystallized goethite (around 380 kOe), can be generally assigned to varying crystallinity of goethite and/or small particles. Poor crystallinity and substitution may modify the spectrum of goethite to such an extent that characterization must be carried out at low temperatures. According level diagram of Gibbs free energies of formation for some corrosion products of iron, α -FeOOH is a level in the transition to α -Fe₂O₃. Also a corrosion product can exist in the outermost layer at sensibility limit of the method. Its presence is suggested by smoothing the spectrum. CEMS spectra indicate a corrosion layer thickness greater than 250 nm. The spectrum of steel substrate was not evidenced.

The surface spectra obtained by CXMS without electron filter give the integral information about superficial corrosion layer. The magnetite and hematite are the compounds of the layer. Magnetite is now the main compound of corrosion layer. The using of the electron filter hides the hematite presence. Also hematite is not presented in surface sample collected by scape method and measured in transmission geometry. The data obtained for sample collected by scape method are very closely with those obtained by CXMS with electron filter. The all CXMS spectra evidenced the steel substrate.

The results of all Mössbauer measurements show the presence of a corrosion layer on initial steel sample. The layer compounds are magnetite, hematite and goethite. The relative concentration in increasing order is: goethite, hematite and magnetite. The goethite and hematite are located at the surface of corrosion layer. We estimate the corrosion layer thickness around 5 microns.

The spectra of the samples ready for electrodeposition show the moving off the corrosion layer and the presence of α -Fe. The Fe sextet have hyperfine parameters, practically the same as for the initial sample, obtained from sample body and measured in transmission geometry. The intensities of the second and fifth peaks of these sextets with respect to the third and fourth peaks, in CEMS spectra, showed that the directions of the γ -ray and magnetic moments were nearly perpendicular and thus indicate a magnetic anisotropy at surface samples. The magnetic moments of iron tend to be orientated in surface plane. By contrast, the TMS and CXMS showed that the magnetic moments inside the sample were in a random arrangement. The anisotropy found in superficial layer of around 250 nm thickness,

by CEMS spectra, is obtained, mainly, due preparation process of steel sheets for galvanization.

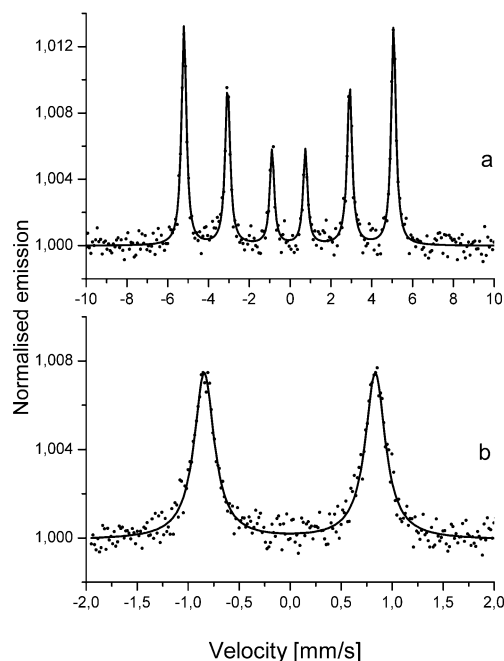

Fig. 6. Mössbauer spectra by CXMS of the electrodeposited sample: (a) at high velocity range; (b) at low velocity range.

CXMS spectra of the electrodeposited sample (Fig. 6), obtained for two velocity ranges, evidenced properly steel substratum and its parameters are practically the same with that obtained before deposition. The spectra did not show the presence of a new intermetallic compound between steel and Zn coating. The spectrum obtained at lower velocity range and greater statistics was used for better detection of possible compounds from interface layer steel – Zn coating.

Conclusions

The possibility to make Mössbauer measurements on steel samples in transmission geometry using ^{57}Fe Mössbauer isotope was proved.

The different flow gas detectors to make superficial measurements in the nano or micro range by Mössbauer spectroscopy using ^{57}Fe Mössbauer isotope have been developed.

The Mössbauer hyperfine parameters for steel samples measured in the both geometries were determined.

The subjects important for steel industry were approached: corrosion in H_2SO_4 aqueous solution; diluted ammoniacal media or HCl solutions in presence or absence of the organic corrosion inhibitors; the composition and structure of a interface layer for a steel sample.

References

- [1] Mössbauer, R.-L., *Nuclear resonance fluorescence of gamma radiation in ^{191}Ir* , Z. Phys., **151**, 1958, p. 124–143.
- [2] Long G. J. and Grandjean F., (Eds.), *Moessbauer Spectroscopy Applied to Magnetism and Materials Science*, vol. 2, Plenum, Dordrecht, 1996.
- [3] Maddock A. G., *Moessbauer Spectroscopy: Principles and Applications of the Techniques*, Horwood Chemical Science Series, Horwood, Chister, 1997.
- [4] Bibicu I., *Mossbauer spectroscopy applied to surface study*, Revue Roumaine de Chimie, **57**, 9-10, 2012, p. 877-889.
- [5] Barb D., Morariu M., Tarina D., Bibicu I., Constantinescu S., Diamandescu L., *Utilizarea efectului Mössbauer in studiul proprietatilor unor oteluri industriale Fe-C*, St. Cerc. Fiz., **25**, 1973, p. 17- 26.
- [6] Barb D., Morariu M., Diamandescu L., Bibicu I., *Internal magnetic fields in Fe-Si electrotechnical steels*, Rev. Roum. Phys., **19**, 1974, p. 425-429.
- [7] Bibicu I., Moisil G.C., Barb D., Romanescu M., *Mössbauer technique for investigating the action of an organic inhibitor of corrosion*, Rev.Roum.Phys., **20**, 1975, p. 531-535.
- [8] Bibicu I., Nat N., Barb D., *Study by Mössbauer Spectroscopy of the Fe-Sn interface from a babbitt bearing*, St. Cerc. Fiz., **41**, 1989, p. 877 – 879.
- [9] Bibicu I., Rogalski M. S., Voiculescu Gh., Nicolescu G., Barb D., *Proportional counter for conversion and transmission Mössbauer spectroscopy*, Rev. Roum. Phys., **37**, 1992, p. 315-317.
- [10] Bibicu I., Rogalski M. S., Nicolescu G., *A detector assembly for simultaneous conversion electron, conversion X-ray and transmission Mössbauer spectroscopy*, Meas. Sci. Technol., **7**, 1996, p. 113-115.
- [11] Bibicu I., Rogalski M. S., Nicolescu G., *Toroidal proportional detector for conversion X-ray and transmission Mössbauer spectroscopy*, Nucl. Instrum. Methods Phys. Res. B, **94**, 1994, p. 330-332.
- [12] Bibicu I., M. S. Rogalski, *Proportional counter for simultaneous conversion X-ray and transmission Mössbauer spectroscopy*, J. Phys. III, **4**, 1994, p. 2495-2499.
- [13] Bibicu I., *An improvement of the toroidal proportional detector for Mössbauer spectroscopy*, Proceedings of the Xth edition of the Conference: “THE ACADEMIC DAYS OF A.S.T.R”, Galati, Romania, ISSN 2066-6586, 2015, p. 226-229.
- [14] Bibicu I., Nicolescu G., Cretu C., *A versatile gas-flow proportional counter for Mössbauer spectroscopy*, Hyperfine Interact., **192**, 2009, p. 85-91.
- [15] Bibicu I., Samide A., Preda M., *Steel corrosion in diluted ammoniac solutions studied by Mössbauer spectrometry*, Mat. Lett., **58**, 2004, p. 2650-2653.
- [16] Samide A., Bibicu I., Rogalski M., M. Preda, *Surface study of the corrosion of carbon steel in solutions of ammonium salts using Mössbauer spectrometry*, J. Radioanal. Nucl. Chem., **261**, 2004, p. 593-596.
- [17] Samide A., Bibicu I., Tutunaru B., Preda M., *Studiul suprafetii oțelului-carbon corodat in ape industriale care contin $\text{NH}_3/\text{NH}_4\text{Cl}$ utilizând spectrometria Mössbauer*, Rev. Chim-Bucharest, **56**, 2005, p. 934-937 (850-853).
- [18] Samide A., Bibicu I., Rogalski M., Preda M., *A study of the corrosion inhibition of carbon-steel in diluted ammonia media using 2- mercapto-benzothiazol (MBT) by Mössbauer spectrometry*, Acta Chim. Slovenica, **51**, 2004, p. 127-136.
- [19] Samide A., Bibicu I., Rogalski M. S., Preda M., *Surface study of the corrosion inhibition of carbon steel in diluted ammonia media using N-ciclohexil-benzothiazole-sulphenamida*, Corros. Sci., **47**, 2005, p. 1119-1127.
- [20] Samide A., Bibicu I., Rogalski M., Preda M., *Studiul inhibării coroziunii oțelului-carbon cu etilentiouree în soluții de clorură de amoniu utilizând spectrometria Mössbauer*, Rev. Chim-Bucharest, **54**, 2003, p. 927-931.
- [21] Patru A., Bibicu I., Agiu M., Preda M, Tutunaru B., *Mossbauer Spectroscopy study on the corrosion inhibition of carbon steel in hydrochloric acid solution*, Mater. Lett., **62**, 2008, p. 320-322.
- [22] Samide A., Bibicu I., Turcanu E., *Corrosion inhibition of carbon steel in hydrochloric acid using n-acetyl p-aminobenzene sulfonamide*, Rev. Chim-Bucharest, **60**, 2009, p. 564-567.

- [23] Samide A., Bibicu I., Turcanu E., *Surface analysis of inhibitor films formed by N-(2hydroxybenzilidene) thiosemicarbazide on carbon steel in acidic media*, Chem. Eng. Commun., **196**, 2009, p. 1008-1017.
- [24] Samide A., Bibicu I., *A new inhibitor for corrosion of carbon steel in hydrochloric acid solution*, Rev. Roum. Chem., **54**, 2009, p. 33-43.
- [25] Patru Samide A., Bibicu I., *Kinetics corrosion process of carbon steel in hydrochloric acid in absence and presence of 2-(cyclohexylaminomercapto) benzothiazole*, Surf. Interface Anal., **40**, 2008, p. 944-952.
- [26] Bibicu I., Bulea C., Diamandescu L., Rus V., Popescu T., Mercioniu I., *Characterization of surface and interface of Fe-C steel under electrolytic galvanisation*, Proceedings of the Romanian Academy - series A, 19, 3, 2018, p. 423-430.