



Technical Sciences
Academy of Romania
www.jesi.astr.ro

Journal of Engineering Sciences and Innovation

Volume 6, Issue 1 / 2021, pp. 31 - 40

<http://doi.org/10.56958/jesi.2021.6.1.31>

A. Mechanical Engineering

Received 9 September 2020

Accepted 14 January 2021

Received in revised form 17 December 2020

Influence of bolts bending on the strength of flanges joints of pressure vessels

GEORGETA ROMAN^{1*}, DRAGOȘ ALEXANDRU APOSTOL²

¹Industrial Process Equipment Department, University POLITEHNICA of Bucharest, Bucharest, 060042, Romania

²Materials Strength Department, "University POLITEHNICA of Bucharest, Bucharest, 060042, Romania

Abstract: This paper highlighted the shortcomings of the current international normative on the calculation of flanges joints with gasket situated inside the circle of bolts holes. The current codes do not take into account, when calculating the flanged joints of the vessels, the bending stress that occurs as a result of the movement of the plates of the joint subjected to internal pressure. The bending of the bolts influences the deformation of the sealing gasket and – namely – the sealing of the flange joint. The knowledge of the bolts bending stresses allows to increase the time between two revisions/repairs and – namely – the useful life of the sealing gasket. The experimental data, obtained with the help of a strain gage bridge and by the Digital Image Correlation method on the designed experimental installation, highlighted the bending of the flange bolts, both for pressurization and depressurization. The experiments were performed at an internal pressure of 0.5; 1.0; 1.5 and 2.0 MPa.

Keywords: flange joints, bolt bending, sealing, Digital Image Correlation.

1. Introduction

Flange joints are mainly used for pressure equipment [1 - 5] but we also find them in some structures not stressed by pressure [6 - 8]. Numerous researches have highlighted various peculiarities of the effects of flange loading. Particular attention was also paid to the sealing of flange assemblies [5].

Concerning the calculations of resistance of the components of the flange joint, which was treated substantially in many design codes, out of which has been enforced the method of ASME normative [1], adopted by European regulations [2,

*Correspondence address: ursegeanina@yahoo.com

3]. The calculations of these codes do not reveal do not show the bending loading of the flange bolts of pressure equipment, although this – in certain circumstances - is important (Fig. 1), as has been shown in [8, 9]. When the flanges are axially loaded, F_{ax} , the bolts undergo both axial stresses as well as bending moments. The value of the stress induced by the bend in the bolt depends on the bolt pretensioning and the flange thickness.

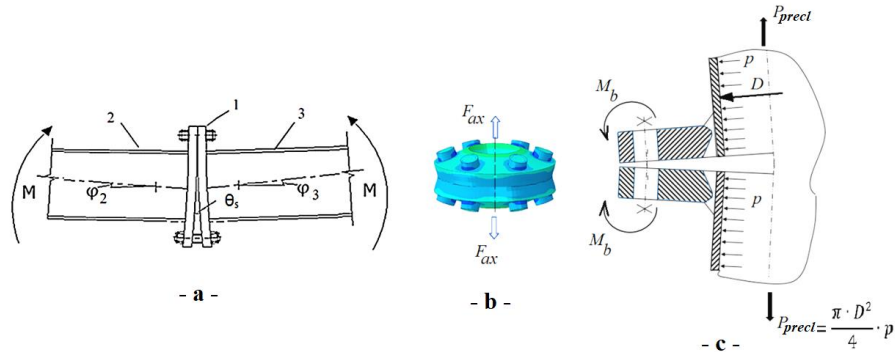

Fig. 1. Additional effects on flanges: a - θ_s further rotation of the flange (1), due to the rotation φ_2 and φ_3 of the pipes 2 and 3 are joined. Flanged bolts joint subjected to bending as a result of their prestressing and the application of axial force F_{ax} applied to pipes which are connected to (b) and preclamping force, P_{precl} produced by the internal pressure, p (c) [6].

The shortcomings of the current methods for calculating flange joints have been shown [10; 11], in which some additions from papers [12 - 19] have been proposed, including, for example:

- consideration of damage to the calculation of the strength or lifetime of flange joints;
- consideration of the fatigue behavior of materials or conditions of creep stress, etc.

It has been shown that the current methods of calculating flange joints do not consider the bending moment produced by the rotation of the flange.

In spite of the classical calculations of flange joints, concerns have arisen regarding the self-disassembly of assemblies in the environment with variable vibrations or fatigue stresses [22; 23], as well as the consideration of the bending action on bolts [24]. Some research refers to the importance of the bending moment which strains the bolts. The more the moment is greater, the radial extension of the flange is larger.

Starting from these findings, in this paper the value of the bending moment of the bolts is determined experimentally, for flat ring flanges welded by cylindrical pressure vessels of different thicknesses.

2. Experimental installation.

A tightening force applied to the flange assembly bolts facilitates the out of plane displacement of the flange, which causes the bolts to bend. Thus, the bending of the bolts

and the relaxation of the gasket lead to a dynamic behavior in the assembly gasket – flanges.

The experiments were performed by using the experimental installation shown in Fig. 2.

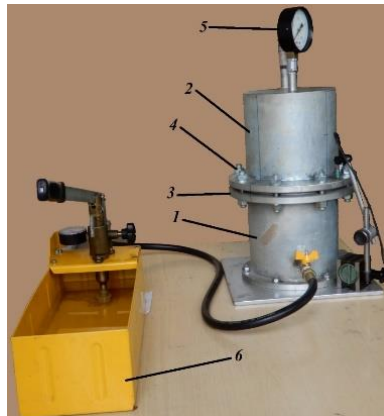

Fig. 2. Experimental installation: 1 - lower cylindrical shell; 2 - the upper cylindrical shell; 3 - flange joint; 4 - bolts; 5 - manometer; 6 - pump [25].

The material from which the flange and cylindrical pressure vessel assembly was made is OL52 (S355 according to SR EN 10025-2: 2004), the bolt material was OLC 45 (1C45 according to SR EN 10025-2: 2004), and the gasket material sealing was klinger (marsit).

The flat flange assembly is provided for the internal pressure $p = 1 \text{ MPa}$ and temperature of $20 \text{ }^\circ\text{C}$, having the following dimensions (Fig. 3): $d_i = 200 \text{ mm}$; $d_e = 220 \text{ mm}$; $s = 10 \text{ mm}$; $d_1 = 310 \text{ mm}$; $d_2 = 270 \text{ mm}$; $d_3 = 18 \text{ mm}$; $d_4 = 221 \text{ mm}$; $b = 20 \text{ mm}$; $n_s = 8 \text{ bolts}$; $c = 248 \text{ mm}$; $b = 20 \text{ mm}$; $b_1 = 16.5 \text{ mm}$.

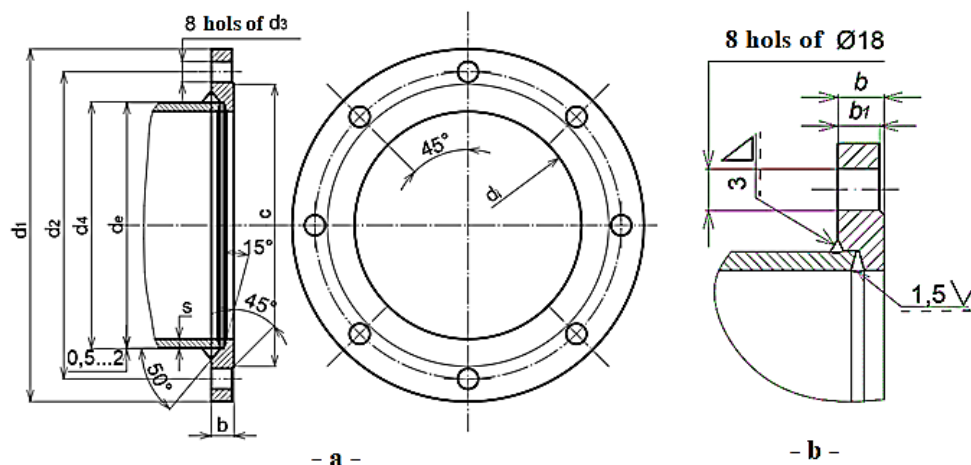

Fig. 3. Flat flange for welding, with a nominal diameter of 200 mm (a); flange detail (b).

The lower cylindrical vessel (1) had a thickness $\delta_1 = 10$ mm and height of 200 mm, being provided with a flat bottom, having a thickness of $\delta_f = 15$ mm. The upper cylindrical vessel (2) had a wall thickness of $\delta_2 = 3$ mm, height of 200 mm and a flat lid with thickness $\delta_c = 3$ mm.

The determination of the bending of the bolts was done by two experimental methods, namely: - with a the strain gage bridge HBM KOMPENSATOR MK, as shown in Fig. 4, and by using the Digital Image Correlation (DIC) method, the Aramis equipment being shown in Fig. 5.

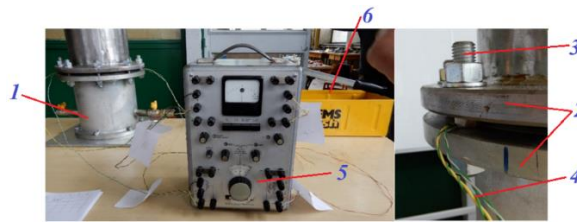

Fig. 4. The experimental installation on which the strain gauges were placed, and the deformation measurement was performed using the HBM KOMPENSATOR MK the strain gage bridge [25]: 1 - the experimental model; 2 - flanges; 3 - bolt; 4 - the connecting cables of the strain gauges to the strain gage bridge 5; 6 - pump.



Fig. 5. ARAMIS system components: Schneider two-chamber sensor (1); two LED lamps (2), stand for supporting and fixing the sensor (3); camera shutter system and image recording control (4); High-performance PC (5) operating under the GOM Linux 7 system and specialized software version 6.1 [26; 27].

- *Strain gauges* with a resistance of 120Ω , with gage length of 3 mm were used to perform the measurements with the help of a Wheatstone bridge. The role of these strain gauges, located on both sides of the bolt rod, was to determine the values of the deformations that appear due to the internal pressures in the vessels (Fig.6).

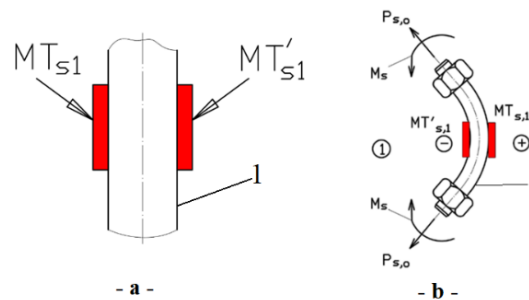

Fig. 6. Strain gauges applied on the bolt (1); MTs1 and MTs2 - strain gauges (a); deformation of the bolt (1) as a result of the application of internal pressure in the vessel (b).

• Digital Image Correlation Method [27]. Fig. 7 shows the photo image as captured by the DIC procedure, after the calibration with a 35/28 mm caliber has been performed, as well as the way to mask (with blue) the areas that will not be analyzed. The area of interest, that is the calculation area is colored green. These images were then analyzed with a software, which performs the actual calibration of the two camera system and also determines the measurement accuracy of the optical system thus assembled.

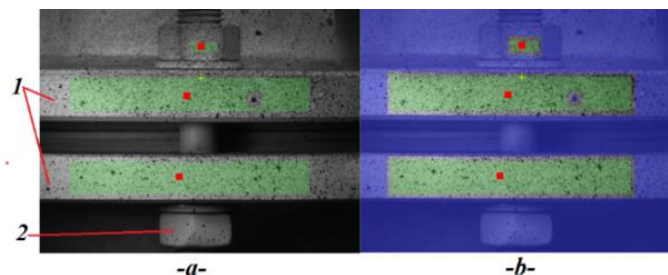

Fig. 7. Camera image (a): 1 - flanges; 2 - bolt (b) and mask image.

The measurements were performed on the bolt with the help of strain gages or next to the clamping bolt by the DIC method.

3. Experimental results.

Experiments were performed to highlight the bending of the bolts: - by pre-clamping with force in the bolt $(P_{s,0})_1 = 0.023 \text{ MN}$; - in operation, at pressures $p = 0.5; 1.0; 1.5; 2.0 \text{ [MPa]}$.

A duration of 5 min was set for stabilizing of the strain.

The values of the specific bolt deformations calculated and those displayed on the gauge bridge screen, as well as the variation of the bolt length obtained by the DIC method, are listed in Table 1.

The experimental determinations were performed both at the pressurization (loading) of the vessel and after it was depressurized (unloading). The characteristic dimensions of the flange assembly are presented in Figure 8.

Table 1. Experimental data obtained with the strain gages placed on the bolt and the variation of the bolt lengths Δl_s , measured at the bolt by the DIC method, for a flange assembly in case of different cylindrical vessel thicknesses $\delta_1 \neq \delta_2$, and the same plate thickness $b_1 = b_2 = 20$ mm ; $l_s = 10$ mm .

	p [MPa]	Strain gages		$\varepsilon(\text{int}) - \varepsilon(\text{ext})$ [$\mu\text{m}/\text{m}$]	Δl_s DIC method [mm]	$\Delta l_s / l_s$ DIC method [%]
		$\varepsilon(\text{int})$ [$\mu\text{m}/\text{m}$]	$\varepsilon(\text{ext})$ [$\mu\text{m}/\text{m}$]			
LOADING	0	0	0	0	0	0
	0.5	25	5	20	0,003	0,03
	1	54	15	39	0.008	0.08
	1.5	82	35	47	0.015	0.15
	2	117	58	59	0.023	0.23
UNLOADING	2	123	80	43	0.022	0.22
	1.5	92	62	30	0.018	0.18
	1	61	44	17	0.012	0.12
	0.5	30	20	10	0.005	0.05
	0	0	0	0	0	0

It is noted for ε – (strain) as following; (int) refers to the vessel wall and the casing (ext) refers to the opposite side of the shell wall.

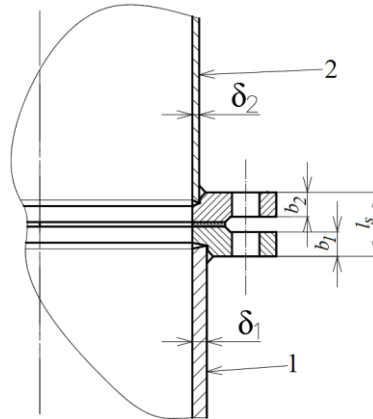

Fig. 8. Flange assembly: b_1 - width of the lower flange plate; b_2 - width of the upper flange plate; δ_1 - the thickness of the lower cylindrical shell of the experimental stand; δ_2 - the thickness of the upper cylindrical shell of the experimental stand; l_s - length of bolt rod;

In Fig. 9 are graphically represented the specific deformations measured at loading and unloading depending on the internal pressure. As it can be seen, the values of the strains measured with the inside strain gauges on the bolt are higher than those on the outside, which proves the bending of the bolts. Larger strains inside than outside lead to bending stresses that can be determined using mathematical calculations. The calculated values of the bending stresses at loading and unloading as a function of the internal pressure are represented in Fig. 10.

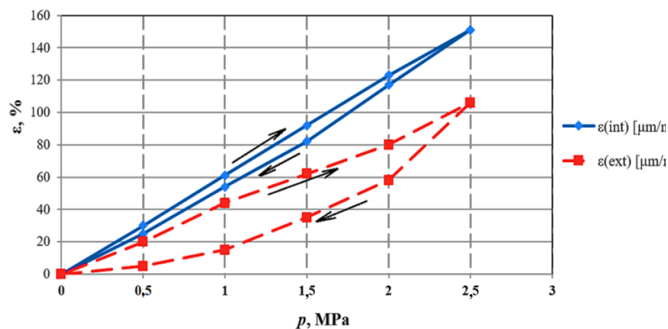

Fig. 9. Specific deformation measured at the bolt (inside and outside) at loading "→" and unloading "←" using strain gages.

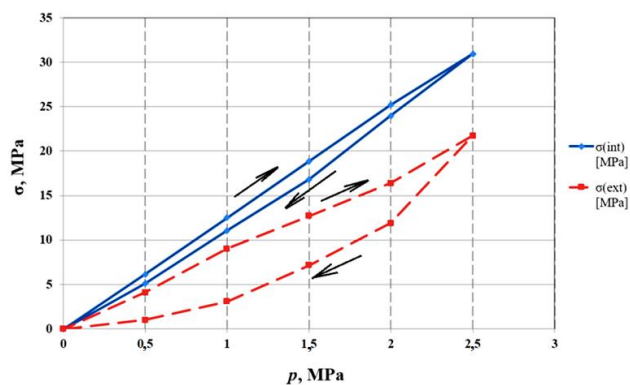

Fig. 10. Calculated values of bending stresses at loading "→" and unloading "←" in bolt, inside and outside.

Also, with the help of the DIC method, the elongation of the bolt is highlighted as a result of the rotation of the flange.

The recording of the experimental results for the two plates of the flange, upper and lower near the bolt, after the gradual variation of the pressure in the vessel are presented in Fig. 11. These experimental data were recorded at both loading and unloading.

The experimental results recorded on both plates showed that they moved negatively on the Y axis. The upper plate recorded a displacement greater than -0.122 mm and the lower -0.099 mm (Fig. 11). This difference in displacement brought the two plates closer by 0.025 mm (Fig. 12). The proximity of the flanges shows us a displacement of them that determines the bending of the bolt and therefore the appearance of the bending stress.

Also, the proximity of the plates leads to the relaxation of the gasket and the loss of the tightness of the flange assembly.

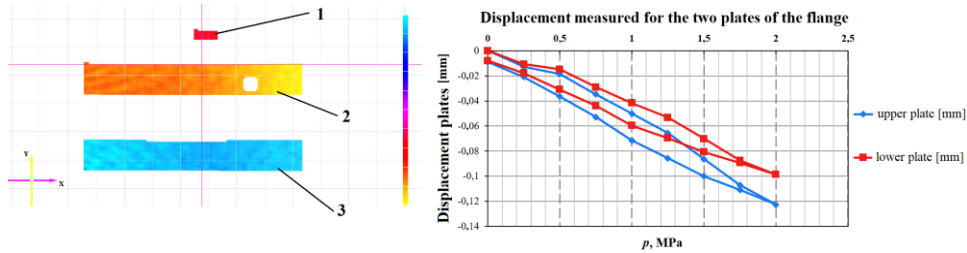

Fig. 11. Displacement measured on vertical direction near the bolt (1) of the upper plate (2) and the lower plate (3) up to a pressure of 2 MPa by the DIC method.

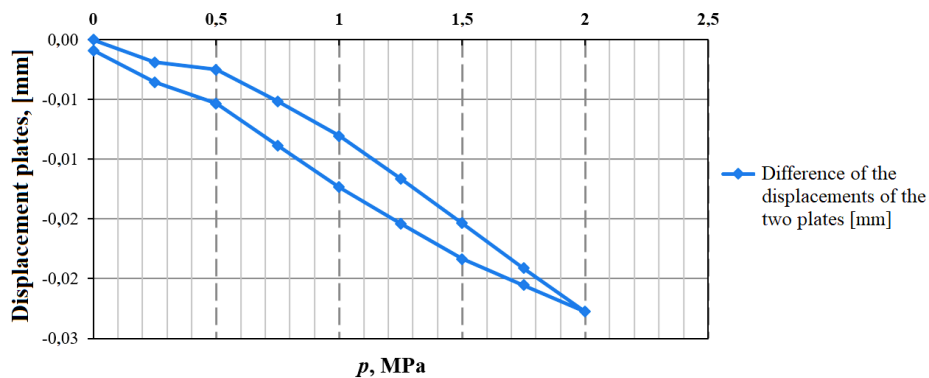

Fig. 12. The difference of the displacements of the two plates measured on Y up to the pressure of 2 MPa by the DIC method.

The negative displacement of both plates is caused by the moments and stresses given by the difference in thickness between the two shells, the upper one having a thickness (3 mm) much smaller than the lower shell (10 mm) of the pressure vessel. This method does not consider the vessel to be a rigid body. Thus the determined values include the total movement of the component parts as a whole. Therefore, it does not only record the movement of the plates but also the movement of the vessel in the area of the plates.

It is possible to eliminate the movement of the vessel, but in this case we are interested in the relative movement of the flange plates.

Table 2 presents, depending on the pressure in the vessel, the values of the total bolt stresses $(\sigma_{s,t})_1$ and $(\sigma'_{st})_1$ based on the deformations measured with the strain gages.

With these calculated:

- bending stresses. For example, for bolt 1 ($k=1$),

$$\sigma_{s,1}^{(b)} = \frac{1}{2} \cdot [(\sigma_{s,t})_1 - (\sigma'_{st})_1];$$

- tensile stress of bolts.

$$\sigma_{s,1} = \frac{1}{2} \cdot [(\sigma_{s,t})_1 + (\sigma'_{st})_1].$$

The same procedure is applied to bolt number 5 which is symmetric to the bolt

number 1.

Table 2. Total stresses $\sigma_{s,t}$ and $\sigma'_{s,t}$, bending stresses $\sigma_{s,k}^{(b)}$ and tractional stress in bolts, $\sigma_{s,k}$, based on experimental data

No.	Pressure [MPa]	Bolt number k	$\sigma_{s,t}$ [MPa]	$\sigma'_{s,t}$ [MPa]	$\sigma_{s,k}^{(b)}$, [MPa]	$\sigma_{s,k}$, [MPa]	$\frac{100 \cdot \sigma_{s,k}^{(b)}}{\sigma_{s,k}}$, %
0.	$p_0 = 0$	1	0	0	0	0	0
		5	0	0	0	0	0
1.	0.5	1	5.123	1.025	2.049	3.074	66.65
		5	4.51	1.025	1.743	2.768	62.96
2.	1.0	1	11.07	3.075	3.998	7.073	56.52
		5	9.635	4.715	2.460	7.175	34.28
3.	1.5	1	16.81	7.175	4.818	11.993	40.17
		5	14.76	8.61	3.075	11.685	26.31
4.	2.0	1	23.985	11.89	6.048	17.938	33.71
		5	21.115	16.81	2.153	18.963	11.35

The experimental data show that the bending stresses represent approximately (from 11.35% to 66.65%) of the bolt stress. Consequently, they must be taken into account in the strength calculations of the pressure vessel bolts.

4. Conclusions

In this paper, the bending of the bolts, which occurred as a result of the displacement of the flange assembly plates subjected to internal pressure, was highlighted, both with the help of strain gage measurements and by the DIC method. This leads to the existence of the bending stresses that can be determined using mathematical calculations.

The bending of the bolts has a negative effect on the gasket of the flange assembly, leading to its relaxation and loss of tightness after several loading-unloading cycles.

Thus, the shortcomings of the current methods of calculating the assemblies with flat ring flanges were highlighted. It turned out that it is important to consider account, when calculating flange joints, the bending stresses that occur in the bolts.

Considering the bending of the bolts allows to increase the duration between two revisions / repairs and - therefore - to increase the life of the sealing gasket.

References

- [1] ASME Boiler and Pressure Vessel Code. Section VIII, Division 2, Rules for construction of pressure vessels, 2010.
- [2] European Standard, *Unfired pressure vessels – Part 3: Design*, EN 13445 – 3, 2009.
- [3] British Standard PD – 5500, *Specification for fusion welded pressure vessels*, 2009.
- [4] Jinescu V.V., – *Calculul și construcția utilajului chimic, petrochimic și de rafinării – Vol. 1*, Ed. Tehnica, Bucuresti, 1983.
- [5] Jinescu V.V., *Utilaj tehnologic pentru industrii de proces – Vol. 3*, Ed. Tehnica, Bucuresti, 1988.
- [6] Urse, G., Durbaca, I., Panait, I.C., *Some research results on the tightness and strength of flange joints*, J. Eng. Sciences and Innovation, **3**, 2, 2018, p 107-130.
- [7] Yapici A., Saracoglu G., *Fatigue analysis of bolted flange joints of a rotary dryer*, – Engineering

- Failure Analysis, **63**, 2016, p. 182–190.
- [8] Blachowski B., Gutkowski W., *Effect of damaged circular flange-bolted connections on behaviour of tall towers, modelled by multilevel substructuring*, Engineering Structures, **111**, 2016, p. 93–103.
- [9] Reza M.S., Bursi O.S., Paolacci F., Kumar A., *Enhanced seismic performance of non-standard bolted flange joints for petrochemical piping systems*, Journal of Loss Prevention in the Process Industries, **30**, 2014, p. 124-136.
- [10] Jinescu V.V., Urse G., Chelu A., *Evaluation and completion the design methods of pressure vessels flange joints*, Rev. Chim. (Bucharest), **69**, 8, 2018, p. 1956 – 1961.
- [11] Jinescu V.V., Chelu A., Urse G., *A method based on the principle of critical energy for calculating flange joints*, Rev. Chim. (Bucharest), **71**, 2, 2020, p. 185 – 190
- [12] Jinescu V.V., *Cumulation of Effects in calculating the Deterioration of Fatigue loaded Structures*, I. J. Damage Mech., **21**, July, 2012, p. 671-695.
- [13] Jinescu V.V., Chelu A., Teodorescu N., Nicolof V.I., *Strength of Tubular Samples and Tubular Cracked Junction Under Combined Loads*, Rev. Chim. (Bucharest), **66**, 11, 2015, p. 1832 – 1836.
- [14] Jinescu V.V., Nicolof V.I., Chelu A., Manea S.E., *Critical stresses, critical group of stresses and strength of tubular structures without and with cracks*, U.P.B. Sci.Bull., Series D, vol. **77**, 2015 p. 165-176.
- [15] Jinescu V.V., Nicolof V.I., *Strength criteria at the tip of the crack*, Engineering Fracture Mechanics, **142**, 2015, p. 108-115.
- [16] Jinescu V.V., Nicolof V.I., Jinescu G., Manea S.E., *Cap. 1: The Principle of Critical Energy is a Transdisciplinary Principle with Interdisciplinary Applications*, in vol. Proceedings of the International Conference on Interdisciplinary Studies (editor Valentina Mihaela Pomazan), INTECH, ICIS 2016, p. 1-23.
- [17] Jinescu V.V., *Fatigue life prediction for simultaneous cyclic loading with blocks of normal stresses and shear stresses* – J. Eng. Sciences and Innovation, **1**, 1, 2016, p. 1-16.
- [18] Jinescu V.V., *Applications in Mechanical Engineering of the Principle of Critical Energy*, Lambert Academic Publishing, Saarbrücken, 2015.
- [19] Jinescu V.V., Nicolof V.I., Teodorescu N., *Effects superposition under imposed deterioration and simultaneous fatigue in different regimes*, I. J. Damage Mech, **26**, 5, July 2017, p. 633-650.
- [20] Jinescu V.V., Chelu A., Nicolof V.I., Manea S.E., *Calculation of the local critical state taking into account the deterioration and the residual stresses*, J. Eng. Sci. and Innovation, **2**, 3, 2017, p. 9-21.
- [21] Jinescu V.V., Chelu A., Nicolof V.I., Roman (URSE) G., *Strength analysis of shells on the basis of principle of critical energy*, Buletin Științific U.P.B, Seria D, Vol. 81, Iss. 3, 2019, p 155 – 168.
- [22] Liu J., Ouyang H., Feng Z., Cai Z., Liu X., Zhu M., *Study on self-loosening of bolted joints excited by dynamic axial load*, Tribology International, **115**, 2017, p 432 – 451.
- [23] Mo Y., Guo S., Qin X., Qin J., Zhan K., Gao X., *Research on the numerical calculation method for antiloosening performance of screwed joints under complex working conditions*, Mathematical Problems in Engineering Volume 2020, Article ID 5915173, 16 pages <https://doi.org/10.1155/2020/5915173>.
- [24] Rafik V., Combes B., Daidié A., Chirol C., *Experimental and numerical study of the self-loosening of a bolted assembly, advances on mechanics*, Design Engineering and Manufacturing II, 2019, p.85-94,
- [25] Roman (Urse) G., *Cercetări referitoare la corelația dintre rigiditatea, rezistența și etanșeitatea asamblărilor cu flanșe plate inelare ale recipientelor sub presiune.* – Teză de doctorat, Universitatea Politehnica Bucuresti, 2019.
- [26] Sandu M., Sandu A., *Captatoare cu traductoare rezistive. Proiectare. Aplicații*, Printech, București, 1999.
- [27] www.resist.pub.ro.
- [28] Hagara M., Schrötter M., *The printed patterns investigation for the purposes of deformation analysis performed by digital image correlation system*, American Journal of Mechanical Engineering, **1**, 7, 2013, p. 185-189.