



Technical Sciences
Academy of Romania
www.jesi.astr.ro

Journal of Engineering Sciences and Innovation

Volume 2, Issue 1 / 2017, pp. 63-82

<http://doi.org/10.56958/jesi.2017.2.1.63>

*B. Electrotehnics, Electronics, Energetics,
Automation*

Received 14 December 2016

Accepted 5 March 2017

Received in revised form 23 January 2017

Intelligent Energy Management in the Galapagos Islands towards a Smart Grid

D. X. MORALES^{1*}, Y. BESANGER², J.P. ERAZO³, R.D. MEDINA⁴

¹ Member IEEE, Ecuador, ²Senior Member, IEEE, France, ³Member IEEE, Ecuador,
⁴Member IEEE, Ecuador

Abstract. The Galapagos Islands are a fragile ecosystem which belongs to Ecuador country. About 26.000 people are located in four islands of the archipelago and approximately 61% of the population is concentrated on Santa Cruz Island. The supply of energy is through of combined technologies such as thermal, photo-voltaic and wind. The government of Ecuador is fostering the policy zero CO₂ emissions within the islands. In order to achieve this objective, some initiatives are carried out like replacing the conventional vehicles and the gas stoves by electrical ones. Taking into account this framework, it becomes vital to assess the impact of these new policies on the distribution network; for sure, this will change significantly the operation and control of Galapagos distribution grid. Hence, this paper proposes an impact study of intelligent Demand Side Management techniques development adapted to the Galapagos context, in order to help to their preservation, reducing the environmental footprint, becoming a world reference in management of the energy and sustainability. Real field informations have been used in the presented models.

Keywords. Smart Grids, LV network, electrical vehicles, induction cookers, Distributed Generation, impact study. Optimal energy management.

1. Introduction

The Galapagos Islands are an archipelago of volcanic islands distributed on either side of the equator in the Pacific Ocean, 926 km west of continental Ecuador, of which they are a part. The Galapagos Islands and their surrounding waters form an Ecuadorian province, a national park, and a biological marine reserve. The principal language on the islands is Spanish. The islands are famed for their vast number of endemic species and were studied by Charles Darwin. His observations and collections contributed to the inception of Darwin's theory of evolution by natural selection. Since 1978, they are accepted as Heritage World.[1]

Due to the growth of the population, there are several social, economic and environmental problems, which endanger the environment conservation of the Islands.

According to the census made on 2010 by the INEC, on the Galapagos province there are 25.124 people, of which 15.393 live at Santa Cruz, 7.475 at San Cristobal and 2.256 at Isabela.[2]



Fig. 1. Galapagos Satellite View [3].

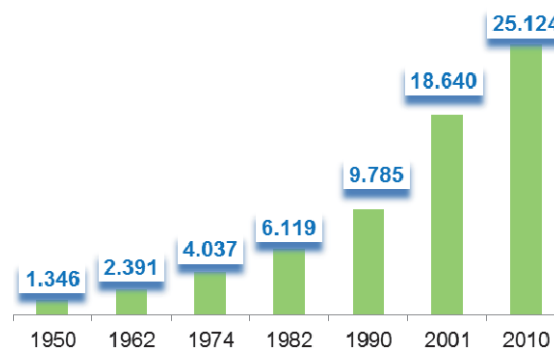

Fig. 2. Evolution of the population in Galapagos.

The Ecuadorian government wants to preserve its ecological heritage, hence with the participation of several stakeholders such as the Ministry of Energy and Renewable Energy, Galapagos Government Council, among others, is releasing a lot of initiatives such as replacing the conventional vehicles by electrical ones and the gas stoves by induction ones, strong integration of distributed generation, deployment of an advanced distribution management system -ADMS- and a future deployment of smart meters in order to improve the general services that are provided in the islands either to the population or to the 180.000 people who visits Galapagos every year. Nowadays, there are so many activities ongoing; these ones are performed by international and national organisms. All of this in order to achieve the Island's sustainability and to reduce the environment footprint. One of these initiatives is the EcoSmart Project [4], which is looking for improving the preservation of the Galapagos Islands and reducing the environmental footprint, becoming a world reference in management of the energy and sustainability. Thus, wishes are to reduce fossil fuel consumption and therefore CO₂ footprint, to improve quality of services and in turn to reduce the environmental

impact thereof, through the use of renewable energies, to balance the generation and consumption. In order to lead the islands through efficiency and quickly transition towards a Smart Grid – *SG* – some ADA functions (Advanced Distribution Automation) such as self-healing, demand side management –*DSM*–, volt-var control –*VVC*–, and network reconfiguration –*NR*– must be implemented. According to [5], a Smart Grid could be defined as “An electricity network that can intelligently integrate the actions of all users connected to it - generators, consumers and those that do both functions to efficiently deliver sustainable, economic and safe power supply”.

Around the world, with the improvements achieved in the Information and Communication Technology –*ICT*– field, the implementation of Smart Grid is more and more recommended in electric power systems. For instance, Denmark, a pioneer in the development of smart grids, concludes in its report [6] that a Smart Grid is the most effective strategy to develop the electrical system and prepare it to meet future challenges. In this context, the first great change is occurring in distribution networks, since distribution networks are the connection point between new agents with the grid [7].

The Ecuadorian electrical sector is aligned with new concepts like distributed generation –*DG*– such as micro and pico hydraulic, photovoltaic, wind and biomass, and new loads such as electric vehicles –*EV*– and induction cookers. The induction cooker is a specific new load in Ecuador, which has been recently deployed into the LV grid to replace gas stoves. 80 induction cookers have already been deployed for the specific case of Galapagos Archipelago and 240 have been requested [8]. The Ministry of Electricity and Renewable Energy of Ecuador is analyzing the possibility to incorporate devices with the ability to measure and control these new loads. Hence, Advanced Metering Infrastructure –*AMI*– technology would collaborate to perform demand side management and to improve agents visibility in the network [9]. One of the main statements within *SG* concepts is the evolution of a passive towards active client, known as prosumer (proactive consumer) [10]. Accordingly, encourage customers for generating their own energy is a key aspect considered within the new policies to convert Galapagos to an archipelago energetically self-sustaining.

The advent of all these challenges must be evaluated in order to measure their impacts on the electrical network. In [11], the assessment of these policies is conducted in the specific case of Galapagos. Due to the demographic characteristics and the existent logistics, this paper will focus on the islands which represent most of the population, i.e. Santa Cruz (61%) and San Cristobal (30%).

2. Demand Side Management

In [11], a detailed study about the impact of electric motorbikes (motorbikes are the most used vehicles in Galapagos), induction cookers and distributed generation, specifically PV panels, is presented. The main results show, for example, that the relative load of one the MV/LV transformer of the Santa Cruz grid reaches 142,12% as maximum, and the transformer is overloaded during almost 2 hours per day (in red in Fig. 3).

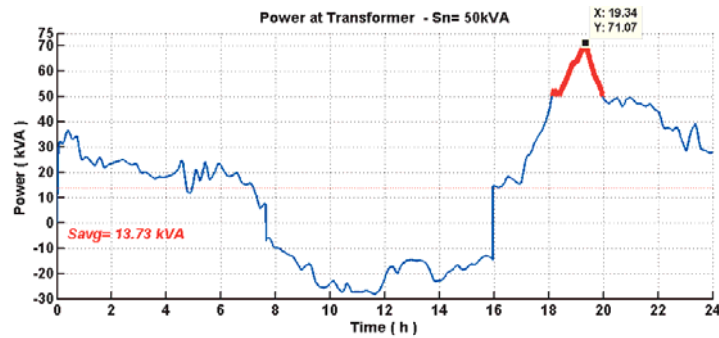

Fig. 3. Active power through a MV/LV transformer.

The reverse flow due to the PV panels installed at households also is depicted. However, as it was expected, the main peak during the night is still present. This clearly shows the need for performing additional techniques like Demand Side Management –*DSM*- in order to reduce the peak at the transformer. *DSM* programs involve an intelligent effort to face the increasing electricity demand, through shifting the peak load and using energy in an effective way. According to [12], an intelligent *DSM* provides us a good approach to realize the optimal management of energy use by means of *i*) advanced communication device, *ii*) regulation methods and *iii*) appropriate economic incentives. Depending on the type of *DSM*, different means of technology, and especially communication, are necessary. *DSM* is seen in [13] as a good promotor of distributed generation: In order to avoid long-distance transport, locally generated energy could be consumed by local loads, immediately when it is available.

The main advantage of *DSM*, taking into account the economical point of view, is that is it less expensive to influence changes in the load than to build a bulk power plant. *DSM* can be classified as following (Fig. 4).

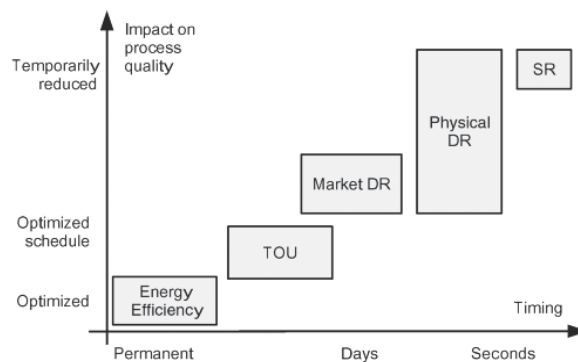

Fig. 4. *DSM* Categories [13].

- a) Energy Efficiency –*EE*;
- b) Time of Use – *TOU*;

- c) Demand Response – *DR*;
 - Market *DR*;
 - Physical *DR*;
- d) Spinning Reserve – *SR*.

A. Energy Efficiency

At the lower level of DSM, all the permanent changes on equipment or improvements on the system are considered in this category. This kind of actions results in immediate and permanent energy and emissions savings. Hence, the Ecuadorian government has launched two initiatives: the first one was to replace the conventional light bulbs by energy saving ones and the second consists in changing the not efficient refrigerator by efficient ones. Indeed, since 2012 in Galapagos, 1053 refrigerators of class D has been replaced by refrigerators of class A, reaching a saving of \$200,754.45 annuals. The goal is to change 3000 refrigerators until 2017.

At the national level, the adoption of these actions made it possible to reach a reduction of 8.6% in the consumption peak by means of 15 million of saving bulbs delivered, 85,000 refrigerators changed, 65,000 street lights replaced, 600 industrial users trained in the standard ISO 50001, 35 factories with efficient energy management systems, 8 standards of Energy Efficiency and 22 regulations of Energy Efficiency. As a consequence, 600 million of investment needed for building bulk power plants were deferred [14].

B. Time of Use

The time of use is an array of static tariffs that penalize with a higher price certain periods of time, generally the peak hours, in order to motivate the customers to re-arrange their processes to minimize the energy cost. It does not mean that it would exist a consumption reduction in all the cases, but a change in the consumption patterns would be registered. In the worst cases, even if we have a reduction of the consumption in a first step, a period known as “rebound effect” (or payback) generally follows, thus the expected energy saving is typically not carried out and maybe even a new peak is generated [13] (see Fig. 5).

In [15], the rebound effect and the energy shifted are taking into account through a shedding vector. The peak could be moved before or after, however it is better to move the peak before the shed time and be prepared. There are two additional options considered as Time-Based rates *i*) Critical peak pricing and *ii*) Real-time pricing. It is worth to mention that the finite customer elasticity and physical situations that are not mapped onto prices lead to the fact that real load shedding cannot be well done only via prices.

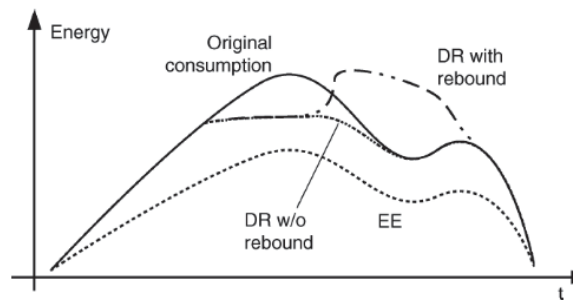

Fig. 5. DSM with and w/o rebound [13].

C. Demand Response

In this kind of DSM, a signal coming from the distribution system operator –*DSO*– is broadcasted to the clients in order to get a much quicker response than TOU. Normally, this signal contains *i*) price of energy *ii*) command for load shedding or shifting.. To perform DR efficiently, a “controller” is required (see Fig. 6), which uses load models for taking good decisions. This can be done in an autonomous way or in a coordinated way, but it not easy to imagine a community of autonomous distributed controllers, without communication, performing load shedding at the same time because DR can cause some issues such as cold load pickup, DR dependency on voltage, and phase imbalance [16]. In addition, using DR with the loads that cannot generate could act as a kind of virtual storage via load shifting [13]. In order to execute automated demand response, a new protocol has been presented recently by OpenADR [17].

Market DR relies on a market place where transactions are done a day ahead considering prices signals and incentives, whereas Physical DR uses emergency signals and takes into account grid management.

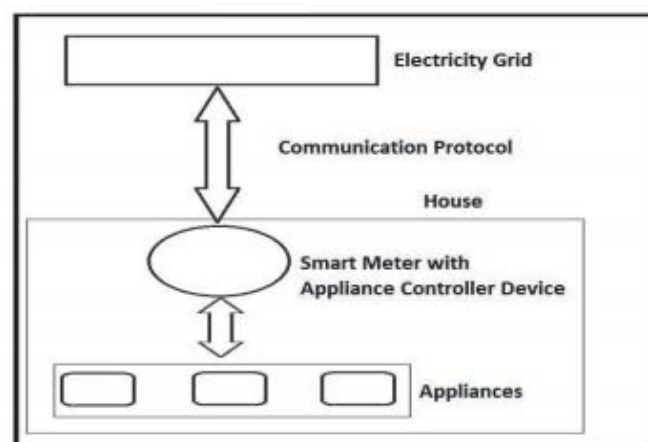

Fig. 6. DR using Appliance controller device [18].

D. Spinning Reserve

The traditional spinning reserve is an ancillary service that corresponds to generators that are in operation (spinning) with additional production capacity that can be produced (injected into the network) in an interval of 10 minutes for at least two hours [19]. So, DSM spinning reserve tries to imitate this behavior; in other words, the load must be reduced or increased when the grid frequency drops or rises.

In [20] is presented a comprehensive load-side frequency control mechanism that can maintain the grid within operational constraints using controllers that can re-balance supply and demand after disturbances, restore the frequency to its nominal value and preserve inter-area power flows.

Based on the Smart Grid concept, the electricity consumption could vary with the changes in the price according to their requirements [12].

3. Intelligent DSM For Galapagos Islands

In this section, the current TOU in Ecuador will be explained; also a proposal developed by the Polytechnic University of Valence for Ecuador is analyzed; after, an intelligent method that combines DR + TOU is presented.

Nowadays, considering all the policies launched by the government, the National Agency Regulation of Ecuador -*ARCONEL*- has updated the tariff schedule in order to include a new tariff for EV (up to 10kw) [21]. See Table I

Table 1 presents the tariff calculated by two variable components and by a fixed one. The variables components *i*) demand, *ii*) energy changes according the day and hour, for instance the consumption in the national peak period (18:00 – 22:00) is the most expensive; demand 4,05 USD/kw and energy 0,10 USD/kwh

Table 1. Tariff for EV

Days/ Hour	Demand (USD/kw)	Energy (USD/kwh)	Commercialization (USD/consumer)
M-F / 8h00 to 18h00	2,43	0,08	1,414
M-S / 18:00 to 22:00	4,050	0,1	1,414
M-S / 22h00 to 8h00	1,458	0,05	1,414
S*-D / 8:00 to 18:00	1,458	0,05	1,414

M = Monday, F = Friday, S = Sunday, S* = Saturday

Assuming that 15% of the loads are controllable [22] and that every household possesses at least one controllable device which participates to the load management. This value is associated with the potential of loads such as air conditioning,

electrical vehicles, washing machines, laundry dryers and dish washers, which generally offer flexibility in time of a few hours.

A polynomial function is created in order to represent the effect of applying TOU according to Table I, and a 50% rebound is integrated into the simulation [23].

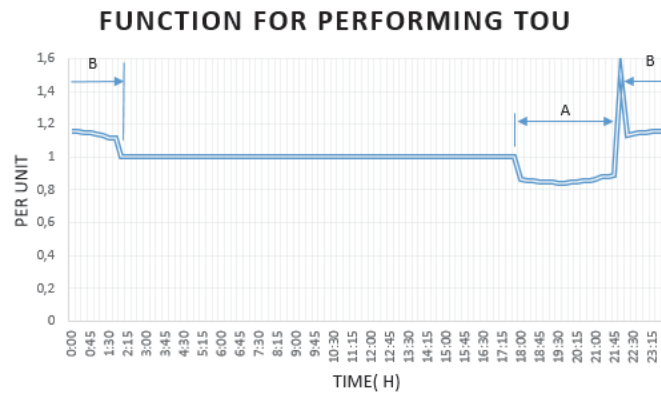

Fig. 7. Weighting function for performing TOU considering the guidelines given by ARCONEL.

The weekly tariff (Monday to Friday) is implemented by the weighting function. The A region from 18:00 to 22:00 is shifted immediately after the most expensive period to the region B where we have the cheapest price, this mean from 22:00 to 08:00. However, the reader should take into account that the energy of 4 hours was shifted. Thus, energy now is consumed between 22:00 and 02:00.

The next figure illustrates the changes caused over an average residential profile, it is possible to identify the rebound and how the load is shifted to the night hours.

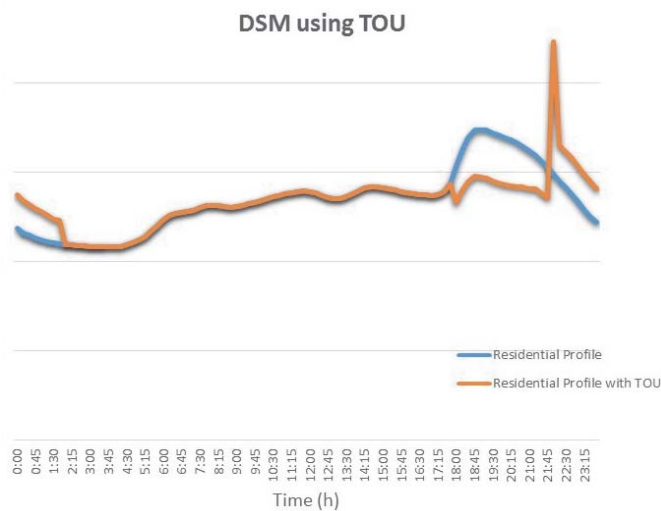

Fig. 8. Comparative curves of residential profile vs residential profile with TOU.

A modification in the model developed in [11] was executed in order to perform DSM, basically, the changes consist in adjusting all the residential curves (40) by means of multiply the curve by the weighting function defined using the information of Table 1.

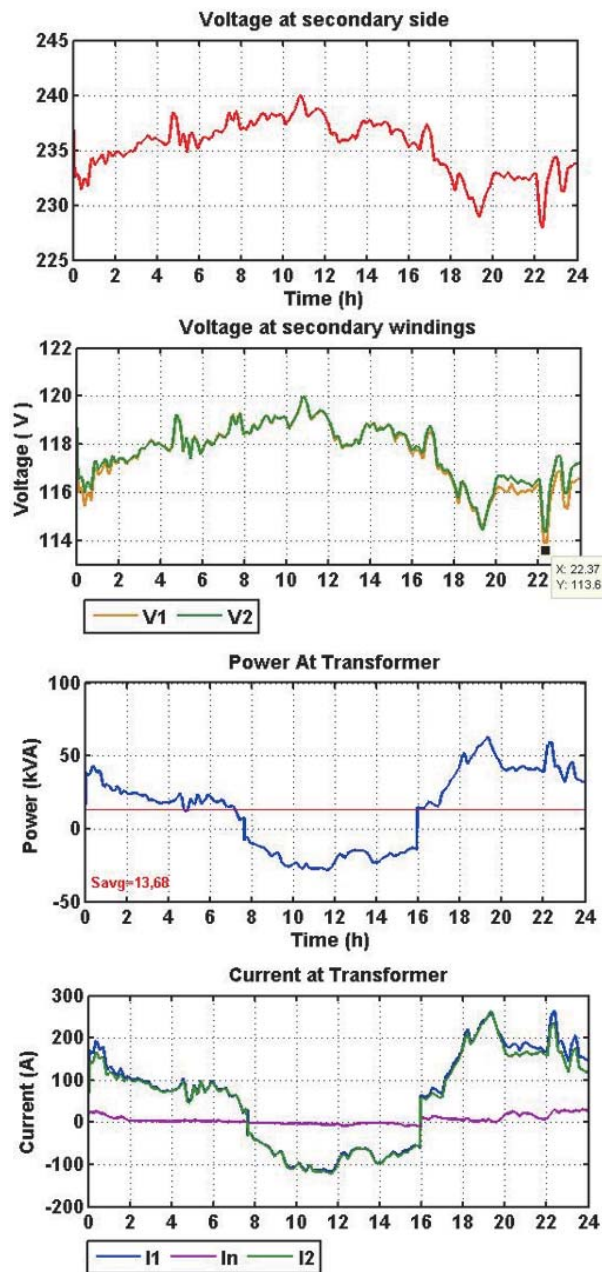

Fig. 9. Results after applying DSM using ARCONEL curve.

As illustrated in Fig. 9, and comparing to Fig. 3, the power peak in the transformer at 19:00 has been decreased to 63,03 kVA, but a new peak at 22:00 is registered (59,7 kVA). The voltages are exceeding the lower limits required by the quality standard (2-phase LV system 120/240V +/- 10%).

A first study about the feasibility of deploying Smart Grids in Ecuador [26] proposes a new TOU schedule considering different profiles in the country, since ARCONEL has been using only a national profile. This methodology is more consistent because it takes into account the real time measurements available at the interconnection points between transmission and distribution, which were taken by the National Center of Energy Management –CENACE–.

Figure 10 depicts the methodology achieving the new profiles.

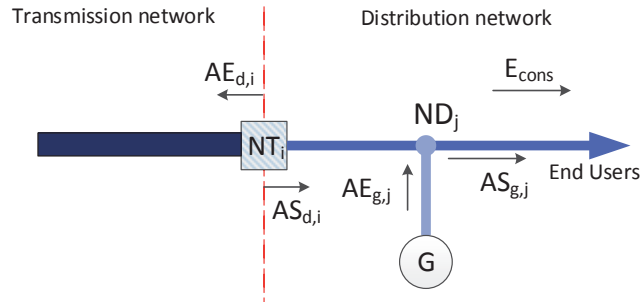

Fig. 10. Methodology for getting the supply power to the end users.

The equation 1 defines the total power delivered to the end users.

$$E_{cons} = \left(\sum_{i=1}^n AS_{d,i} + \sum_{j=1}^m AE_{g,i} \right) - \left(\sum_{i=1}^n AE_{d,i} + \sum_{j=1}^m AS_{g,i} \right) \quad (1)$$

where,

E_{cons} = Total power delivered to the end users connected at the distribution network;

$AS_{d,i}$ = Power delivered coming from the transmission network to the distribution network at the node NT_i;

$AE_{d,i}$ = Power delivered coming from the distribution network to the transmission network at the node NT_i;

$AE_{g,j}$ = Power delivered to the distribution network by the generators connected at the node ND_j;

$AS_{g,j}$ = Demand of the elements connected at distribution network at the node ND_j

n = Transmission nodes;

m = Distribution nodes with a generator connected.

Once defined the methodology and the equation needed, several profiles are determined for 6 regions in Ecuador , *i*) Cost, *ii*) Sierra, *iii*) Amazon, *iv*) Quito, *v*)

Guayaquil and vi) Galapagos; those profiles are divided by week, weekend and holidays as well as season. For the purpose of this paper, only a typical profile will be considered (weekly profile during summer). Then, a new TOU schedule is defined in the same way than previously.

In [24], after performing an in-depth analysis on the monotonic curve, three periods are identified and the peak period (P1) is located between 09:00 and 21:00. Then, a new simulation considering the described above is performed. The main curves are depicted in the next figures.

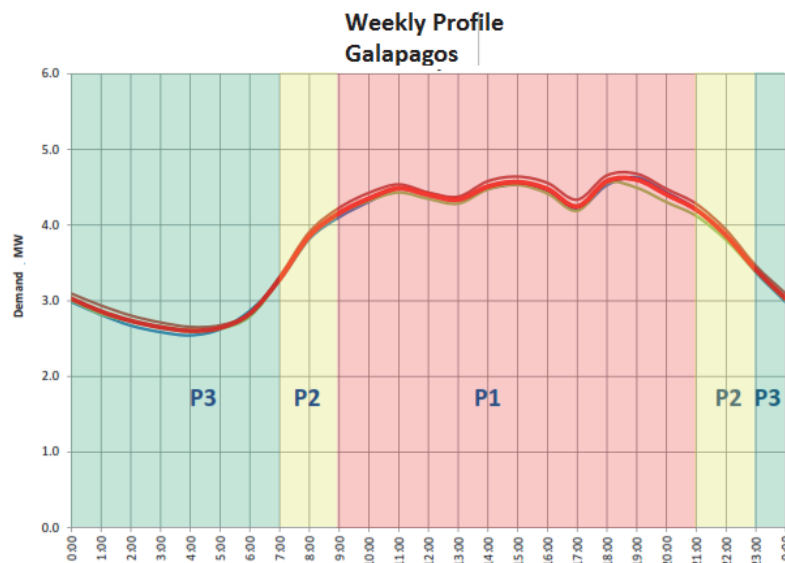

Fig. 11. TOU defined by real measurements.[24]

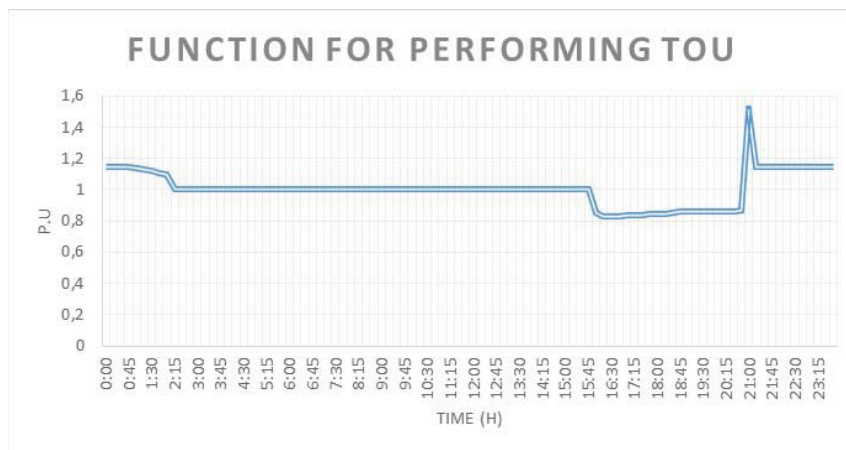

Fig.12. Weighting function for performing TOU considering the guidelines given by the study performed to deploy Smart Grids in Ecuador -UPV-

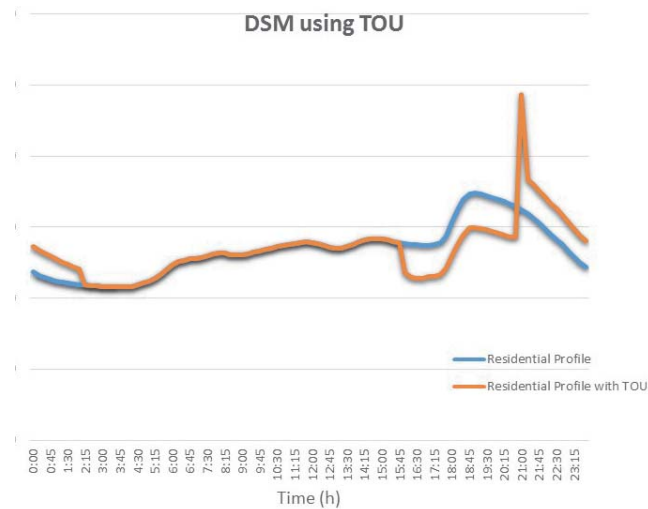

Fig.13. Comparative curves of residential profile vs residential profile with TOU defined by regions.

As we can see in the next figure a higher peak (74, 31 kVA) at 21:00 is registered. The voltages are worst compared with the previous scenarios and the limits accepted by the quality standard are violated (minimum 111.3V).

Obviously, the rebound causes this increase in the peak. Hence, a smart strategy must be implemented in order to avoid the peak as well as to shift the energy during the whole day and not only after the peak period. Therefore, the previous weighting function is modified until to reach a soft function, which has the same energy during the whole day with the difference that now, it will be considered an appliance controller device in each household and the shifted energy will be consume during the whole day. It is worth to mention there are two key technologies enabling demand side load Optimization *i*) Building automation and *ii*) Smart metering + Appliance controller.

In the previous paragraph, it was defined a 15% of controllable loads, the loads normally are classified as:

- Baseline loads refers to those appliances that must be activated immediately at any time, or maintained at 'Stand by' mode. Their economic value doesn't allow any intelligence integration, and they are not controllable because they depend on consumer behavior and comfort [24]. Lighting, TV, and computing are some examples.
- Regular loads are those corresponding to the appliances that are operated for long time periods like fridge and water heater.
- Burst loads concerns the appliances that must operate for a limited time period within deadlines. This last type can be flexible and so delayed to start operation in another moment, like washing machine, dryer dishwasher, air conditioning and EV.

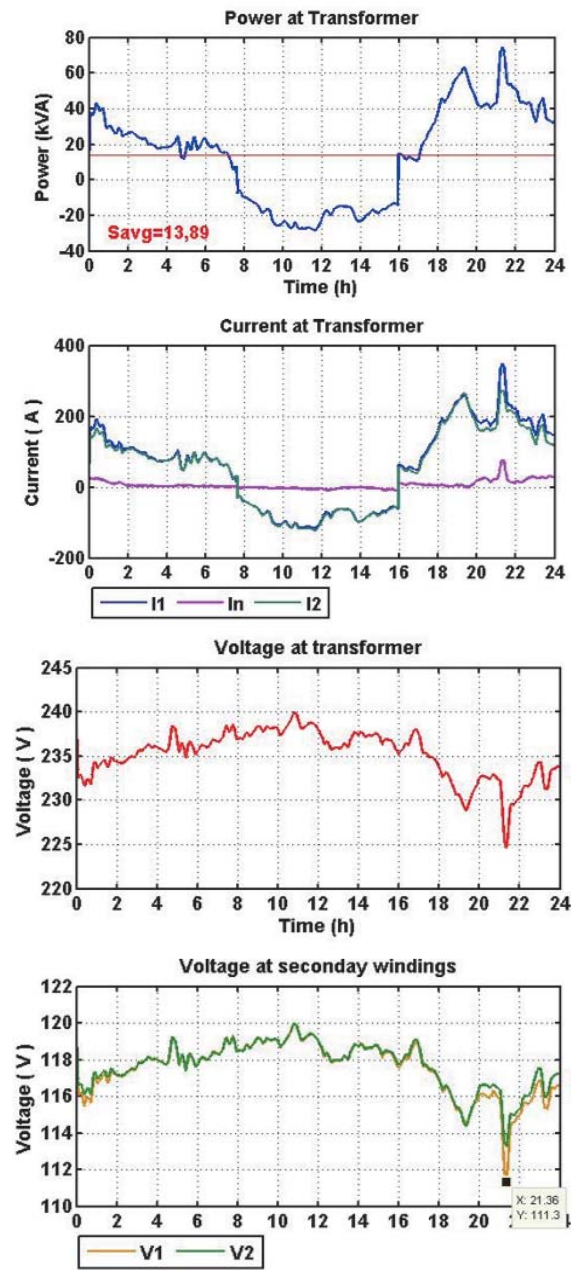

Fig. 14. Results after applying DSM using UPV curve.

The peak load problem is mainly caused by regular and burst loads combination. In addition, DSM programs could be classified as traditional or as modern ones. The next figure shows the ways to perform DSM. The items *a*, *b* and *c* are considered as traditional ways and on the other hand, the items *d*, *e*, and *f* are modern techniques.

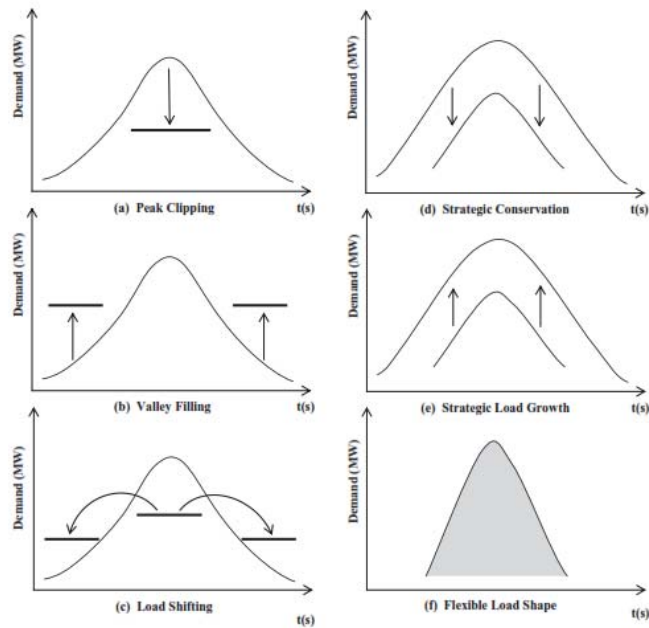

Fig. 15. Load Shapes for DSM program [25].

Thus, the smart strategy will consider only actions over the burst loads and will use a modern DSM program (TOU + DR), thus, no more rebound (f program). See Figure.16.

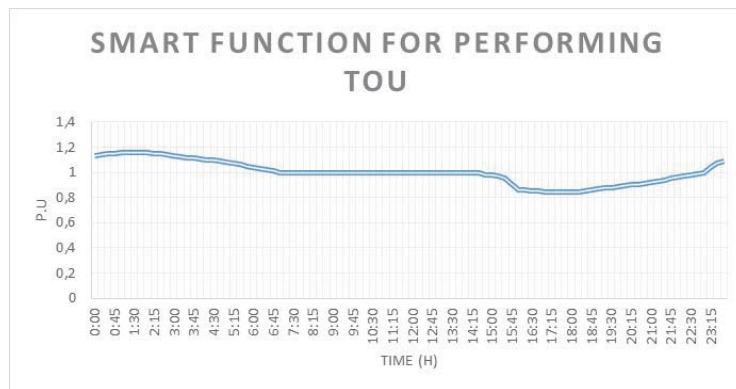

Fig.16. Smart function for performing DSM.

Using the profiles affected by the smart function, another simulation is performed. Fig. 17 shows the main curves of active power and voltages. As we can see, the peak generated by the rebound in the previous scenarios is annulated due to the consideration of an installed controller at the households and ought to a smart technique for DSM.

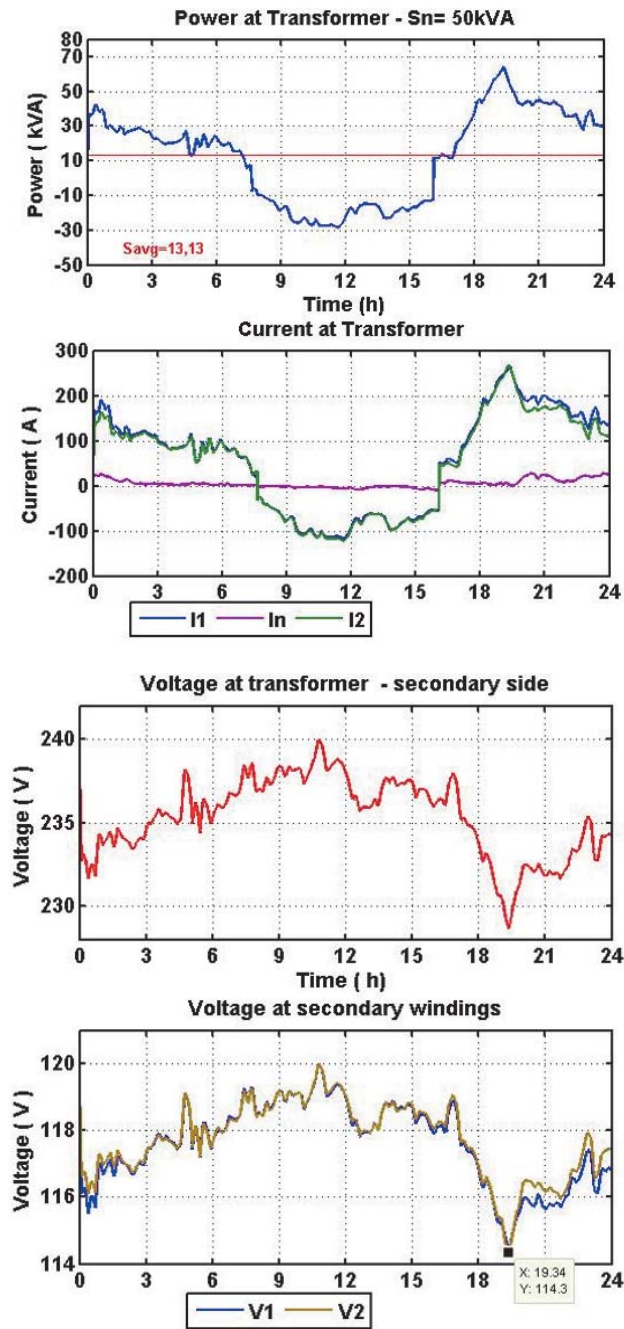

Fig. 17. Results after applying intelligent DSM.

In this scenario, all the limits are respected and the lowest peak is registered.

4. Results

A. Scenarios

Reference [10] presents several scenarios that were created in order to assess the impact of different services. This paper aims to determine the impact of the DSM program, therefore, additional scenarios are created. A summary of the initial scenarios is presented.

The nomenclature is:

PQ = Load fed with Active and Reactive power curves.

IC= Induction Cooker

EM= Electrical Motorbike

G = Growing of population, therefore of the load.

PV= Photovoltaic panel

TOU ARCONEL = DSM with the schedule defined by ARCONEL

TOU UPV = DSM with the schedule defined by the study to deploy Smart Grids in Ecuador

TOU Smart = DSM with a soft and intelligent function.

1. Scenario PQ

This scenario represents the current situation.

2. Scenario PQ+IC

An induction cooker is implemented for each residential client.

3. Scenario PQ+IC+EM

An electrical motorbike for each client is added to the previous scenario

4. Scenario PQ+IC+EM+G

This scenario considers an annually growing of population leading to a 8,5% increase of the load [26].

5. Scenario PQ+IC+EM+G+PV

Taking advantage of the existence of solar resources, an array of PV panels [27] is connected in each client.

6. Scenario TOU ARCONEL

Upon the scenario 5, a DSM program is simulated, here the weighting function defined in the figure 7 is considered. The 40 load curves are affected by the weighting function.

7. Scenario TOU UPV

Upon the scenario 5, a DSM program is simulated, in this case the polynomial function defined in the figure 12 is considered. Therefore, the 40 load curves feeding the model are affected by this function.

8. Scenario TOU Smart

Upon the scenario 5, a DSM program, which considers all the premises about DSM techniques and percentage of controllable load, as well as the types of load, is simulated. In this case, the smart polynomial function of the figure 16 is considered for modifying the 40 load curves of the model.

B. Analysis and Discussion of the Results

As it was expected until the scenario 4, the average power at the transformer grows. However, in the scenario 5, due to the installation of PV panels, this average decreases of almost 60%, but we still have the same peak during the night. Whereby, the scenario 6, which considers a DSM program, achieves a peak of 63.03kVA (12% reduction compared with the scenario 5). The scenario 7 has a peak at 21:00 of 74.40 kVA (4% of increase compared with the scenario 5), this scenario is the worst because it has the highest peak and the lowest voltage. The last scenario (8) is an intelligent DSM program, which is able to remove the peak created by the rebound and to shift the energy during the whole day keeping the average power at the transformer. The next figure shows the results for each scenario.

Scenario	Name	V1			V2			Power (kVA)			Overload
		Max	min	Avg	Max	min	Avg	Max	min	Avg	Max
1	PQ	119,94	116,40	117,59	120,34	116,69	117,71	36,96	0,35	24,40	0,74
2	PQ + IC	119,94	114,84	117,08	120,34	114,88	117,21	56,05	0,35	30,13	1,12
3	PQ + IC + EM	119,94	114,06	116,99	120,34	113,99	117,13	66,81	0,35	31,39	1,34
4	PQ + Growing	119,94	113,58	116,71	120,34	113,48	116,87	71,06	0,35	33,77	1,42
5	PQ + PV	120,01	113,58	117,54	120,34	113,48	117,67	71,06	-28,38	13,73	1,42
6	TOU arconel	120,01	113,58	117,55	120,34	114,36	117,68	63,02	-28,38	13,68	1,26
7	TOU rebote	120,01	111,30	117,51	120,34	113,29	117,66	74,40	-28,38	13,89	1,49
8	TOU smart	120,01	114,37	117,59	120,34	114,31	117,72	64,07	-28,38	13,13	1,28

Fig. 18. Results of the different scenarios.

In terms of overload, the best scenario between DSM scenarios (6, 7, and 8) is the 7 with 126%. Nevertheless, scenarios 6 and 7 do not comply the quality regulation, where is defined the lower limit at 114V at the secondary side. The scenario 7 is the worst.

In terms of voltages levels, the scenario 8 is the better, because it respects the quality regulation all the time, the reduction of the peak is around 10% compared with the scenario 5. Also, in terms of overload, it is a really good solution because the obtained value is 128%, very near to scenario 6.

According to [28], an acceptable value during two hours is an overload of 133%. Finally, the scenarios 5, 6, 7 and 8 inject current through the transformers due to the reverse flows originated by the PV panels. The next figures show a comparative analysis between the DSM programs in reference to the active power and voltages.

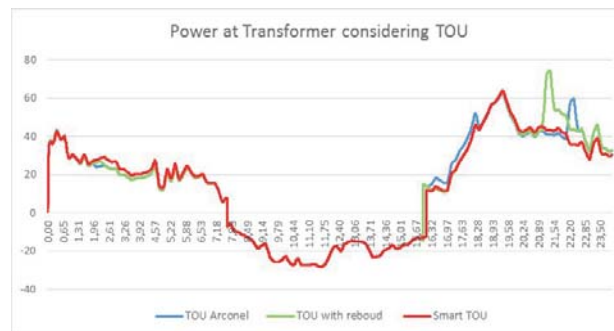

Fig. 19. Comparative Analysis: Power at Transformer.

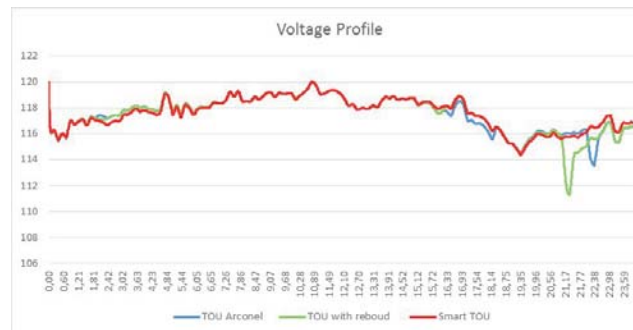

Fig. 20. Comparative Analysis: Voltage Profile.

According Fig. 19 and Fig.20, scenario 8 is the best option to perform DSM, having a small overload and voltage level within the accepted limits.

5. Conclusions

In this paper, a study of the impact of different DSM programs on the low voltage network of Galapagos Islands has been carried out. Real data curves have been used such as residential load, PV production, and induction cookers, with a real part of LV Galapagos network, in order to make the simulations most realistic as possible.

In order to implement an intelligent DSM, the main assumption is that each household has an appliance controller device installed, which controls the burst loads such as air conditioning, washing machine and EV; since the electrical vehicles are mainly expected to be charged at home or during working time, the time slots between 5 am and 8 am and between 4 pm and 8 pm in the defined polynomial functions are appropriate. It was demonstrated by means of intelligent DSM that the effects generated by the rebound could be neutered.

The future works will seek to build the smart architecture needed to implement the simulations in the real life as well as an innovative technique to reduce the imbalance. Finally, energy storage systems will be analyzed in order to get a complete smart grid model in low voltage.

One can notice that for the purpose of the study, a powerful interface between GIS and Simulink has been developed to facilitate the carrying out of several analysis with different scenarios and topologies, and a Simulink library was created with new blocks for considering the Galapagos reality.

References

- [1] E. Travel. (2016). *Galapagos Islands EcoTourism*. Available: http://www.ecuador.us/travel/galapagos_islands/info/galapagos_islands_ecotourism/
- [2] INEC. (2015). *Ecuador en Cifras - Población y Demografía*. .
- [3] G. Earth, *Galapagos's Satellite View*, ed. <https://www.google.com/earth/>, 2016
- [4] AYESA, *EcoSmart Galapagos*, A sustainable city, 2014.
- [5] United State Department. of Energy. (2016). *What is the Smart Grid* Available: https://www.smartgrid.gov/the_smart_grid/
- [6] Energinet.dk, *Smart Grid in Denmark*, 2011.
- [7] D. X. Morales, R. D. Medina, and Y. Besanger, *Proposal and requirements for a real-time hybrid simulator of the distribution network*, in 2015 CHILEAN Conference on Electrical, Electronics Engineering, Information and Communication Technologies (CHILECON), 2015, pp. 591-596.
- [8] Ministerio de Electricidad y Energia Renovable, *Dashboard Cocinas de Inducción*, in Ministry of Electricity and Renewable Energy of Ecuador, M. o. E. a. R. E. o. Ecuador, Ed., ed. <http://gis-sigde.maps.arcgis.com/apps/dashboard/index.html#a84655ed31fc407bb9afdfc0dae968c6>, 2015.
- [9] S. Huibin, S. Ying, and L. Wei-Jen, *A demand side management model based on advanced metering infrastructure*, in Electric Utility Deregulation and Restructuring and Power Technologies (DRPT), 2011 4th International Conference on, 2011, pp. 1586-1589.
- [10] G. Ritzer and N. Jurgenson, *Production, Consumption, Prosumption The nature of capitalism in the age of the digital 'prosumer'*, *Journal of consumer culture*, vol. 10, pp. 13-36, 2010.
- [11] D.X Morales , Y. Besanger, C. Alvarez , R.D. Medina, *Impact Assessment of New Services in the Galapagos Low Voltage Network*, *IEEE T&D Latin-America*, Morelia-Mexico, 2016.
- [12] X.-t. Chen, Y.-H. Zhou, W. Duan, J.-b. Tang, and Y.-x. Guo, *Design of intelligent Demand Side Management system respond to varieties of factors*, in *Electricity Distribution (CICED), 2010 China International Conference on*, 2010, pp. 1-5.
- [13] P. Palensky and D. Dietrich, *Demand Side Management: Demand Response, Intelligent Energy Systems, and Smart Loads*, *IEEE Transactions on Industrial Informatics*, vol. 7, pp. 381-388, 2011.
- [14] M. d. E. y. E. Renovable, "Rendición de Cuentas 2015," 2015.
- [15] V. GOUIN, "Evaluation de l'impact du Smart Grid sur les pratiques de planification en cas d'insertion de production décentralisée et de charges flexibles," Ph.D, Université Grenoble-Alpes, France, 2015.
- [16] J. Medina, N. Muller, and I. Roytelman, "Demand Response and Distribution Grid Operations: Opportunities and Challenges," *IEEE Transactions on Smart Grid*, vol. 1, pp. 193-198, 2010.
- [17] M. A. Piette, *Automated Demand Response to Enable the Integration of Renewable Resources*, 2015.
- [18] L. Kaira, M. Nthontho, and S. Chowdhury, *Achieving demand side management with appliance controller devices*, in Power Engineering Conference (UPEC), 2014 49th International Universities, 2014, pp. 1-6.
- [19] J.-C. S. Nouredine Hadjsaid *Power System and Restructuring* vol. I. United States: John Wiley & Sons Inc., 2009.
- [20] E. Mallada, C. Zhao, and S. Low, *Optimal load-side control for frequency regulation in smart grids*, in Communication, Control, and Computing (Allerton), 2014 52nd Annual Allerton Conference on, 2014, pp. 731-738.
- [21] *Esquema tarifario para la introducción de vehículos eléctricos en El Ecuador*, ARCONEL, 2015.

- [22] U. P. d. Valencia, *Análisis para la implementación de redes inteligentes en Ecuador : Definición Cuantitativa*, Instituto de Ingeniería Eléctrica 2015.
- [23] G. Project. (2015). *Un premier retour sur expérience*. Available: <http://greenlys.fr/>
- [24] U. P. d. Valencia., *Modelo Conceptual para la Implementación de Redes Inteligentes en Ecuador: Aspectos Técnicos y Económicos*, Universidad Politécnica de Valencia 2015.
- [25] E. H. Et-Tolba, M. Maaroufi, and M. Ouassaid, *Demand side management algorithms and modeling in smart grids A customer's behavior based study*, in Renewable and Sustainable Energy Conference (IRSEC), 2013 International, 2013, pp. 531-536.
- [26] ARCONEL. (2015). Estadísticas del Sector Electrico - Demanda Anual.
- [27] U. P. d. Valencia., *Análisis para la implementación de redes inteligentes en Ecuador*, Insituto de Ingeniería Energética, Universidad Politécnica de Valencia, 2015.
- [28] F. E. B. D. Office, *Permissible loading of oil-immersed transformers and regulators, in facilities instructions, standards, and techniques*, vol. 1-5, ed. Denver, Colorado, 2000, p. 28.