



Technical Sciences  
Academy of Romania  
www.jesi.astr.ro

## **Journal of Engineering Sciences and Innovation**

Volume 6, Issue 3 / 2021, pp. 349-358

<http://doi.org/10.56958/jesi.2021.6.3.349>

### **H. Inter – and Transdisciplinarity in Science and Technology**

Received 30 April 2021

Accepted 14 September 2021

Received in revised form 5 July 2021

## **The limitations of energy accessibility, the irreversibility and two transdisciplinary principles**

**Valeriu V. Jinescu\***

*University Politehnica of Bucharest, Industrial Process Equipment Department,  
Splaiul Independentei, 313, Bucharest, Romania*

**Abstract.** The ability to produce motion based on man-made energy is essential to the civilization. Equally important is the most efficient use of energy to limit the consumption of natural resources as well as the resulting pollution. Consequently, it is necessary to know: - the factors that limit the energy accessibility; - the physical bases of irreversibility, as a premise of ensuring the maximum efficiency. The paper presents two new transdisciplinary principles: - the principle of energy accessibility, which introduces the concepts of degree of energy accessibility, degree of energy inaccessibility caused by natural conditions and degree of energy inaccessibility induced by technical conditions; - the principle of irreversibility which introduces the concept of degree of energy irreversibility in correlation with the physical bases of irreversibility.

**Key words:** energy; degree of irreversibility; energy accessibility; degree of energy inaccessibility; efficiency; transdisciplinary principles.

### **1. Introduction**

The principles and laws underpinning the work of Nature are the fruit of Divine creation. We humans witness the wonders of creation and from time to time we manage to discover and formulate some of these principles and laws, which we call of Nature. Two of these transdisciplinary principles that underpin the work of Nature, which I have formulated in the wake of research into many processes and phenomena, are to be presented further down.

In all the chapters of science, interactions were analyzed based on the concepts of loading (forces, stresses, flows, potential difference etc.). The nature of the load imparted specific features to each field. Each of these fields features its own laws of matter behavior and its own principles.

---

\*Correspondence address: [vvjinescu@yahoo.com](mailto:vvjinescu@yahoo.com)

This triggers the challenge of developing a generally valid theory, independent of the load nature (mechanical, electrical, magnetic, thermal, chemical, biochemical, social etc.). This is possible by resorting to a concept that runs through all the fields of science, namely the concept of energy, *E*. One should add to all these the *postulate* that: “*any physical body under load has at least two effects, of which one is - always - the thermal effect*”.

That is the reason why any process, by reversal, cannot bring the matter involved to its initial state. It follows that any process of deformation, flow etc. is irreversible. There are no reversible processes in nature. From the analysis of the physical bases of irreversibility in a certain volume of matter, one has found that irreversibility can be internal and / or external [1].

*The internal irreversibility* is determined by molecular cohesion (internal friction), molecular adhesion (external friction), matter compressibility and binding energy at the molecular, atomic or nuclear level (it corresponds to the heat of reaction at each level of matter).

*The external irreversibility* corresponds to heat transfer and mass transfer through the interface between the matter volume under consideration and the environment. The heat transfer occurs in the direction of temperature decrease and the mass transfer (diffusion) occurs in the direction of decreasing the concentration of the diffusing substance. Starting from the physical bases of irreversibility and energy accessibility, I stated the following transdisciplinary principles of Nature: - *the principle of energy accessibility*; - *the principle of irreversibility*.

The principle of energy accessibility shows the *degree of energy accessibility of an energy source*, taking into account the limitations produced by the environment in which it is located and the technical level attained, and their influence about the efficiency.

The principle of irreversibility shows the *degree of energy irreversibility involved* in a process and allows the maximization of the process efficiency.

In the literature were examined for example: the critical factors of energy efficiency on the global scale [2], an energy supply reliability index [3], factors affecting exergy destruction and engine efficiency of various classes of fuel [4]; analysis of the underground coal gasification [5]; the effect of urbanization on energy and use and efficiency in China [6], efficiency gains and economic growth [7] etc.

The obtained results may be better if takes account on the factors limiting the energy accessibility, as well as the physical bases of irreversibility, like this is presented in the paper.

## **2. The principle of irreversibility**

The principle of irreversibility has been stated as follows:

*“In its development, any process or phenomenon is irreversible and is characterized by the degree of irreversibility of the energy involved, which is positive and subunitary.”*

*The degree of irreversibility* is defined by the equation,

$$\xi_{ir} = \frac{E_{ir}}{E_a}, \quad (1)$$

where  $E_{ir}$  is the energy amount irreversibly transformed by the internal irreversibility ( $Q_{ir,i}$ ) and by the external irreversibility corresponding to the transfer of matter to the outside ( $Q_{ir,e}$ ),

$$E_{ir} = Q_{ir,i} + Q_{ir,e} \cdot \delta_{ir}. \quad (2)$$

Factor  $\delta_{ir} = 1$  if  $c_i > c_e$  and  $\delta_{ir} = 0$  if  $c_i < c_e$ , where  $c_i$  is the concentration of the diffused substance inside the volume and  $c_e$  is the concentration of the substance outside the matter volume, such as,  $Q_{ir,e} \sim (c_i - c_e)$ .

$E_a$  is the amount of *action energy* received from the outside by the matter volum,

$$E_a = W + E_{ir}, \quad (3)$$

where  $W$  is the work produced in the matter volume. In general,

$$0 < \xi_{ir} < 1. \quad (4)$$

In the ideal (reversible) processes  $\xi_{ir} = 0$ , while in the totally irreversible processes  $\xi_{ir} = 1$ . In the deformation process of a perfectly elastic body  $\xi_{ir} = 0$ , while in the flow of a perfectly viscous fluid,  $\xi_{ir} = 1$ . For viscoelastic bodies (viscous behavior prevails)  $\xi_{ir} \in (0.5; 1.0)$ , while for elastoviscous bodies (elastic behavior prevails)  $\xi_{ir} \in (0; 0.5)$ .

The value of the irreversibility degree may be limited for technical, economic or environmental pollution reasons (thermal or diffused substances) according to the equation,

$$\xi_{ir} \leq (\xi_{ir})_{al}, \quad (5)$$

where  $(\xi_{ir})_{al} \leq 1$  is the maximum allowable value of the degree of irreversibility.

The classical treatment of the irreversibility problem envisages thermodynamic systems, by resorting to Clausius's concept of entropy. It cannot be used in systems that are far from a state of equilibrium, a fact emphasized by Prigogine [8; 9].

*The introduction of the concept of degree of irreversibility and its correlation with the internal and external frictional heat, as well as with the energy irreversibly dissipated due to the non-uniformity of intensive quantities, allows the quantitative assessment of irreversibility for any process or phenomenon, whether in a state of equilibrium or far from a state of equilibrium.*

By irreversibly converting energy into heat, the action energy  $E_a$  gets "degraded". It may be said that the irreversibility of energy is at the origin of the non-existence of immortality and the impossibility of going back in time. *Irreversibility is associated with time, because the energetic deterioration of matter occurs over time.*

Consequently, it is fair to say that *irreversibility makes the future different from the past*; the arrow of time directed from the past, through the present to the future is due to the irreversible transformation of energy into any phenomenon or process.

• In an organ of a living body as well as in certain technical processes, the energy corresponding to the internal irreversibility,  $Q_{ir,i}$ , is used to maintain the internal energy,  $U$ , at a certain value and to transfer a certain amount of heat,  $Q_{ex}$  (Fig. 1), to the outside, through the interface,

$$Q_{ir,i} = \Delta U + Q_{ex}, \quad (6)$$

where  $Q_{ex} = k_t \cdot (T_i - T_e)$ , with  $k_t$  - the total heat transfer coefficient, and  $\Delta U$  - the momentary variation of the internal energy.

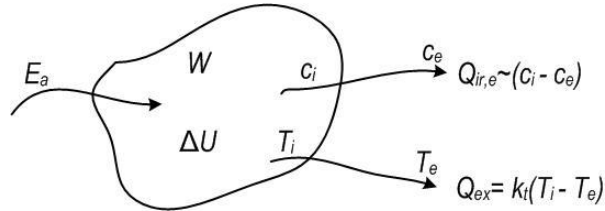

Fig. 1. The effects of action energy,  $E_a$ , on a body:  $W$  – work;  $\Delta U + Q_{ex} = Q_{ir,i}$  – the energy due to internal irreversibility, where  $\Delta U$  is the internal energy variation and  $Q_{ex}$  – heat transfer to the outside;  $Q_{ir,e}$  – energy corresponding to the transfer of matter to the outside.

We may conclude, for example, that the internal energy of a living organ varies between a minimum value  $U_{min}$ , before receiving energy  $E_a$  and a current value  $U(t)$  at a given time,  $t$ , after receiving energy  $E_a$ , so that

$$\Delta U = U(t) - U_{min}. \tag{7}$$

In the organ of a living body (Fig. 1),

$$E_a = W + (\Delta U + Q_{ex}) + Q_{ir,e},$$

where the last two terms ( $Q_{ex} + Q_{ir,e}$ ) correspond to the external irreversibility, and  $\Delta U$  comes from the internal irreversibility.

• The efficiency of a certain process is defined by the equation (Fig. 1)

$$\eta_p = \frac{W}{E_a}. \tag{8}$$

From equations (1), (3) and (8) one obtains

$$\eta_p + \xi_{ir} = 1, \tag{9}$$

which means that

“the efficiency and the degree of irreversibility of the energy involved in any process coexist and are complementary”.

The higher degree of irreversibility is, the lower the ability of an energy source to produce work will be.

• The analysis of natural phenomena and processes shows that Nature operates with minimal energy losses. For example: - a body falls in the gravitational field vertically and not on a certain curve, i.e. on the shortest path, the one with minimum energy consumption; - the movement of an object on an inclined plane follows the line of the steepest slope, i.e. on the shortest way and with the lowest energy consumption; - in front of several channels, the fluid “chooses” the channel with the lowest flow resistance, hence, the lowest energy consumption etc.

Consequently, in order to produce a certain work,  $W$ , with minimum action energy consumption,  $E_a$ , it is necessary that the irreversibly converted energy be minimal,

$$E_{a,min} = W + E_{ir,min}.$$

In other words, in Natural phenomena and processes, the degree of irreversibility is minimal,

$$\xi_{ir,min} = \frac{E_{ir,min}}{E_n}, \quad (10)$$

and the efficiency, according to equation (9), is maximum,

$$\eta_{p,max} = 1 - \xi_{ir,min}. \quad (11)$$

This explains the tendency towards maximum performance of everything that moves in Nature, as shown in the *constructal* theory [10; 11].

*The degree of irreversibility allows the quantitative evaluation of the irreversibility and the comparison of any two processes with one another.*

Taking into account the results obtained in paper [12], one may accept the application of this principle not only to macroscopic irreversibility, but to microscopic irreversibility, too.

- The general equation (9) corresponds to those processes where the energy dissipated irreversibly in heat is a loss; it is not useful. There are processes (eg. extrusion of plastics) where the energy dissipated in the form of heat is useful. In this case only the heat transferred through the interface between the material volume and the environment,  $Q_{ex}$ , will not participate in the process. Consequently,  $E_{ir} \equiv Q_{ex}$ , and instead of  $\xi_{ir}$  one introduces the concept of *reported heat lost to the environment*,

$$\xi_l = \frac{Q_{ex}}{E_n}. \quad (12)$$

According to the general equation (9),

$$\eta_p + \xi_l = 1. \quad (13)$$

The lower the amount of heat transferred through the interface, the higher the process efficiency.

### 3. The principle of energy accessibility

In general, we have access only to a part of the energy available at a given time (also called absolute value energy). How much, is determined from the transdisciplinary principle of energy accessibility:

*“We have no access to absolute value energy, we only have access to the difference in energy between two points in space at a given time, or at a point in space between two successive moments.”*

When we analyse the problem of free energy, or zero-point energy we must take into account the principle of energy accessibility.

**a.** By way of a first example, one may consider the fall in the gravitational field of a body of mass  $m$ . We do not have access to the potential energy in relation to the Earth center (absolute energy,  $E_{ab}$ ) but only in relation to the Earth surface. The potential energy of the body at height  $H$  above the Earth is  $E_p = m \cdot g \cdot H$ , where  $g$  is the gravity acceleration (Fig. 2), is the *maximum accessible energy*  $E_p = E_{ac,max}$ . In the fall, some of the potential energy, as a result of friction with the air, is irreversibly converted into heat,  $Q_{ir}$ .

At ground impact, the kinetic energy is  $E_c = 0.5m \cdot v^2$ . From the energy balance relation,  $E_p = E_c + Q_{ir}$ , we get the speed at ground impact,

$$v = \left( 2 \cdot \left( gH - \frac{Q_{ir}}{m} \right) \right)^{0.5} . \quad (14)$$

When falling in vacuum  $Q_{ir} = 0$ , so that the speed at ground impact is  $v_v = \sqrt{2 \cdot gH}$ .

When falling on a hill of height  $h$  above ground level (Fig. 2), the *accessible potential energy* is  $E_{p,ac} = m \cdot g \cdot H_1$ , where  $H_1 = H - h$  – which shows the limitation of the accessible potential energy caused by environmental conditions ( $h$ ).

The energy corresponding to the difference  $(E_p - E_{p,ac}) = m \cdot g \cdot h$  represents the *inaccessible or not accessible energy caused by the natural (environmental) conditions*, and is written as

$$E_{nac}^{(nat)} = m \cdot g \cdot h. \quad (15)$$

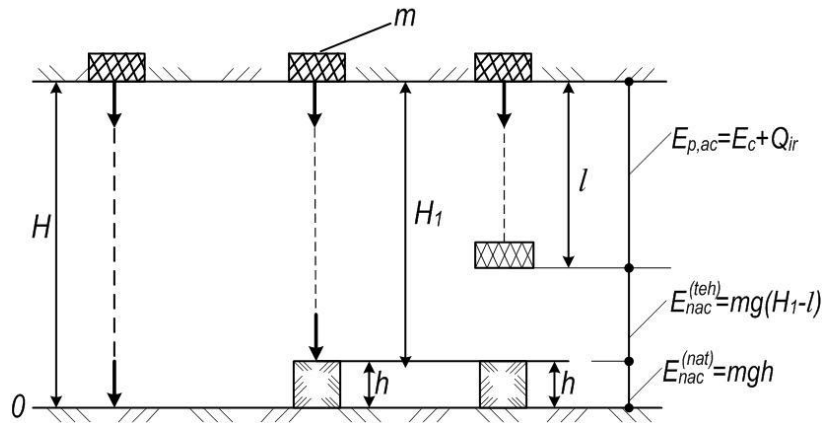

Fig. 2. The potential energies, or accessible energies, corresponding: to the height  $H$  above the Earth,  $E_p$ ; to the height  $h$  above ground level,  $E_{p,ac}$ , and at the end of a cable of length  $l < H_1 - h$ .

The inaccessible energies are caused by natural (environmental) conditions,  $E_{nac}^{(nat)}$ , and by technical conditions  $E_{nac}^{(teh)}$ .

If the body of mass  $m$  is connected to a cable of length  $l < (H - h)$  and falls onto the hill of height  $h$ , then the actually accessible gravitational energy is  $E_{p,ac} = m \cdot g \cdot l$ , and the energy that is inaccessible *because of natural conditions* is  $E_{nac}^{(nat)} = m \cdot g \cdot h$ . The potential energy difference corresponding to distance  $(H_1 - l)$  represents the energy made inaccessible *by technical conditions*,

$$E_{nac}^{(teh)} = m \cdot g \cdot (H_1 - l). \quad (16)$$

One may write that,

$$E_p = E_{p,ac} + E_{nac}^{(teh)} + E_{nac}^{(nat)}, \quad (17)$$

where  $E_p = E_{p,max} = E_{ac,max}$  is the maximum accessible potential energy. It has the role of action energy,  $E_a$ . After dividing it by  $E_{ac,max}$  in equation (17) one gets,

$$\xi_{ac} + \xi_{nac}^{(teh)} + \xi_{nac}^{(nat)} = 1, \quad (18)$$

where

$\xi_{ac} = \frac{E_{p,ac}}{E_{ac,max}}$  is the maximum possible degree of energy accessibility of;  
 $\xi_{nac}^{(teh)} = \frac{E_{nac}^{(teh)}}{E_{ac,max}}$  - the degree of energy inaccessibility from a *technical* viewpoint;  
 $\xi_{nac}^{(nat)} = \frac{E_{nac}^{(nat)}}{E_{ac,max}}$  - the degree of energy inaccessibility caused by *natural* conditions.

The particular case in Figure 2 is generalized in an energy diagram (Fig. 3).

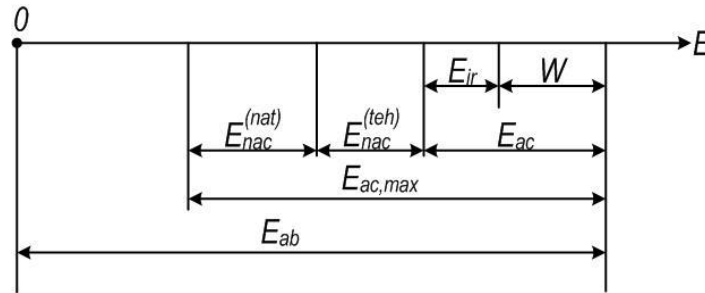

Fig. 3. The correlation between the absolute value of energy,  $E_{ab}$ , maximum accessible energy,  $E_{ac,max}$ , effective accessible energy,  $E_{ac}$ , inaccessible energy from technical conditions,  $E_{nac}^{(teh)}$ , and inaccessible energy from natural conditions,  $E_{nac}^{(nat)}$ . The effectively accessible energy,  $E_{ac}$ , is converted, inside any process, in work  $W$  and into irreversibly transformed energy,  $E_{ir}$ , which determines the internal energy variation,  $\Delta U$ , and the heat transfer outside the body volume,  $Q_{ex}$  (Fig. 1).

From relation (18) one results the degree of energy accessibility that characterizes a certain energy source,

$$\xi_{ac} = 1 - \left( \xi_{nac}^{(teh)} + \xi_{nac}^{(nat)} \right). \tag{19}$$

One has found that both the *natural (environmental) conditions and the technical level attained, at a certain moment, set a limit to the access of the whole amount of energy of an energy source.*

As a consequence of the principle of irreversibility, the energy accessible  $E_{ac}$ , during a certain process, is converted into irreversibly transformed energy,  $E_{ir}$ , and into energy of ordered motion, corresponding to the maximum possible work,  $W$ . On the energy diagram (Fig. 3) the principle of energy accessibility of a source refers to the whole axis of energies, while the principle of irreversibility refers only to the  $E_{ac}$  segment, in connection with a certain process (in which only the actually accessible amount of energy,  $E_{ac}$ , of the energy source, can be used).

**b.** In a *thermal process*, from the absolute thermal energy of the hot source (calculated in relation to the temperature 0K)  $Q_c(T_c)$ , the amount of heat  $Q_r(T_r)$  is given off to the cold source, of temperature  $T_r$ . *The effectively accessible thermal energy* is

$$Q_{ac} = Q_c(T_c) - Q_r(T_r). \tag{20}$$

This is converted into work  $W$  and the irreversibly dissipated energy  $Q_{ir}$  (Fig. 4).

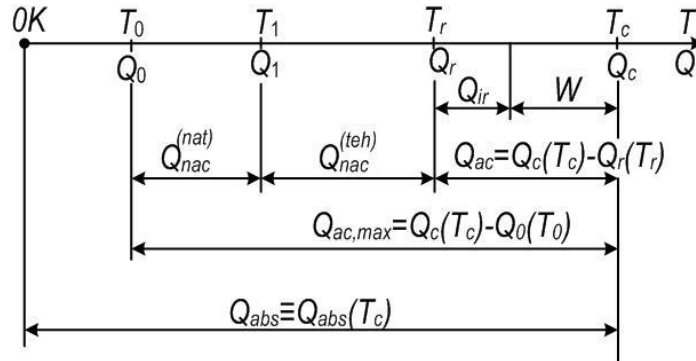

Fig. 4. The correlation between energies in a thermal process, similar to the general case presented in Figure 3: absolute thermal energy,  $Q_{abs}$ ; maximum accessible thermal energy,  $Q_{ac,max}$ , inaccessible thermal energy from technical conditions,  $Q_{nac}^{(teh)}$  and from natural conditions  $Q_{nac}^{(nat)}$ .

The effectively accessible thermal energy,  $Q_{ac}$ , is converted in the work  $W$  and in the irreversible transformed thermal energy,  $Q_{ir}$ , which we find as internal energy variation  $\Delta U$  and heat transferred outside to the interface,  $Q_{ex}$  (Fig. 1).

The maximum accessible thermal energy is

$$Q_{ac,max} = Q_c(T_c) - Q_0(T_0), \tag{21}$$

where  $T_0$  (in K) is the ambient temperature. The *technically inaccessible thermal energy* is,

$$Q_{nac}^{(teh)} = Q_r(T_r) - Q_1(T_1), \tag{22}$$

where  $T_1$  is the minimum accessible temperature for the thermal process.

The thermal energy made *inaccessible by natural conditions* (environmental limitation) is

$$Q_{nac}^{(nat)} = Q_1(T_1) - Q_0(T_0), \tag{23}$$

which is imposed by the ambient temperature  $T_0$ . This limits the complete energy transformation of a thermal energy source. In the case of thermal machines  $\xi_{nac}^{(teh)}$  indicates the reserve, in the cold source area, likely to increase the total efficiency.

c. At a “point” in space, at time  $t_0$ , the amount of local energy is  $E(t_0)$ . At  $t_1 > t_0$ , the amount of local energy may become  $E(t_1)$ .

The maximum local energy accessible until moment  $t_1$  corresponds to the difference (Fig. 5),

$$\Delta E_{ac,max}(t_1) = E(t_0) - E(t_1). \tag{24}$$

Locally, at a given moment, the whole amount of energy is not accessible to us, but only the difference in energy between two successive moments. And in this case the equation (17) is valid if written in the form



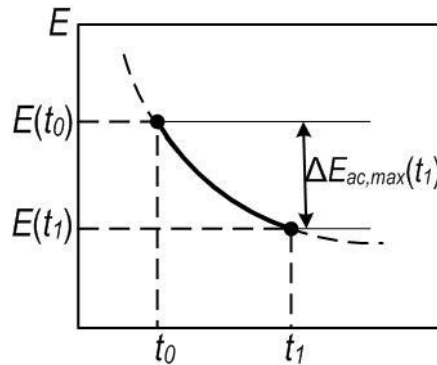

Fig. 5. The possible local energy variation in time,  $E(t)$ . During the time interval  $(t_1 - t_0)$  in a “point” in space the energy variation, or the maximum local energy accessible is  $\Delta E_{ac,max}(t_1)$ .

$$\Delta E_{ac,max}(t) = \Delta E_{ac}(t) + \Delta E_{nac}^{(teh)}(t) + \Delta E_{nac}^{(nat)}(t). \quad (25)$$

Relation (19) is also valid, such as,

$$\xi_{ac} = \frac{\Delta E_{ac}(t)}{\Delta E_{ac,max}(t)}; \xi_{nac}^{(teh)} = \frac{\Delta E_{nac}^{(teh)}(t)}{\Delta E_{ac,max}(t)}; \xi_{nac}^{(nat)} = \frac{\Delta E_{nac}^{(nat)}(t)}{\Delta E_{ac,max}(t)}.$$

Sometimes, erroneously, it is considered that the energy made inaccessible for technical reasons is irreversible energy and is thus included in the calculation of a process efficiency.

The principle of energy accessibility brings clarity to the issues of energy efficiency.

#### 4. Who was right, Aristotle or Galileo Galilei?

If we take irreversibility into consideration, one might give an answer to the above question.

Aristotle stated that, “*heavier objects (with a larger mass) fall to the Earth at a higher speed than light ones.*” According to equation (14), when bodies fall through the air, part of the potential energy is irreversibly converted into frictional heat,  $Q_{ir}$ . If heavy, identical bodies, in shape and volume (which have the same  $Q_{ir}$ ), the ratio  $Q_{ir}/m$  is lower than in light ones, so that the rate of fall of the heavier body is higher than that of the lighter ones. Aristotle was right about the bodies falling into the air.

Galileo Galilei stated that, “*if we neglect air resistance, bodies fall in the same way.*”

He referred to the fall of bodies in a vacuum, in which case  $Q_{ir} = 0$  and consequently the rate of fall  $(\sqrt{2g \cdot H})$  does not depend on the weight of the body. Galileo Galilei was right as well.

## 5. Conclusions

There have been highlighted the physical bases of the internal and external irreversibility of any process or phenomenon (molecular adhesion and cohesion, binding energy, heat transfer, substance transfer).

*The principle of irreversibility*, stated in the paper, introduces the dimensionless concept of degree of irreversibility, which can take values between zero and 1.0, depending on matter behavior. The problem of limiting the degree of irreversibility and its influence on the efficiency has been analyzed.

*The principle of energy accessibility* introduces the dimensionless concepts of the degree of possible energy accessibility, the degree of energy inaccessibility from a technical point of view and the degree of energy inaccessibility caused by natural or environmental conditions. The provisions of this principle have been illustrated for the gravitational potential energy, for the energy of a heat source and for the local energy at a point in space. It was found that the technical level attained, as well as the natural or environmental conditions in which the energy source is located limits the access to the source energy.

The two principles, transdisciplinary principles, put forth in the paper may represent a new approach to correctly assessing the problems of irreversibility, the limitation of thermal pollution and energy accessibility.

## References

- [1] Jinescu V.V., *Energia, Energonica și Termodinamica*, AGIR, Bucharest, 2016.
- [2] Popkova Elena G., Sergi Bruno S., *Energy efficiency in leading emerging and developed countries*, Energy, **221**, 15 April 2021; Article 119730.
- [3] Lingmin Chen, Jiekang Wu, Fan Wu, Huiling Tang, Yan Xiong, *Energy flow optimization method for multi-energy system oriented to combined cooling, heating and power*, Energy, **220**, 22 August 2020, Article 118536.
- [4] Liu Daojian, Wang Hu, Liu Haifeng, Zheng Zunqing, Yao Minga, *Identification of factors affecting exergy destruction and engine efficiency of various classes of fuel*, Energy, **221**, 15 November 2020, Article 118897.
- [5] Eftekhari Ali Akbar, Wolf Karl Heinz, Rogut Jan, Bruning Hans, *Energy and exergy analysis of alternating injection of oxygen and steam in the low emission underground gasification of deep thin coal*, Applied Energy, **208**, 2017, p. 62-71.
- [6] Sheng Pengfei, Guo Xiaohui, *Energy consumption associated with urbanization in China: Efficient - and inefficient – use*, Energy, **165**, 15 December 2018, Part B, p. 118-125.
- [7] Sakai M., Brockway P.E., Barret J.R., Taylor P.G., *Thermodynamics Efficiency Gains and their Role as a Key 'Engine of Economic Growth*, Energies, **12**, 2019, p. 110. <https://doi.org/10.3390/en12010110>
- [8] Kondepudi D., Prigogine I., *Modern Thermodynamics*, John Wiley&Sons ed., Chichester, New York, Toronto, Singapore, 1998.
- [9] Petrescu St., *Tratat de Inginerie Termică. Principiile Termodinamicii*, AGIR, Bucharest, 2007.
- [10] Bejan A., Zane J., *Design in nature*, Anchor Books ed., A Division of Random House, Inc., New York, 2012.
- [11] Bejan A., Lorente Sylvie, *Design with Constructal Theory*, John Wiley&Sons Inc. ed., Hoboken, New Jersey, 2008.
- [12] Lucia U., *Macroscopic irreversibility and microscopic paradox: A constructal law analysis of atoms as open system*, Sci. Rep. 2016;6:35796; doi:10.1038/srep35796