



Technical Sciences
Academy of Romania
www.jesi.astr.ro

Received 29 September 2021

Accepted 7 March 2022

Received in revised form 19 January 2022

Applying knowledge in the field of structural materials degradation from large pressurized reactors to small modular reactors

**DUMITRA LUCAN^{1,4*}, ȘERBAN CONSTANTIN VALECA^{1,3,4,5},
GHEORGHÎA JINESCU^{2,4}**

¹*Institute for Nuclear Research, Campului no.1, Mioveni, POB 78, Arges, Romania*

²*Politehnica University of Bucharest, Polizu Street no. 1-7, Bucharest, Romania*

³*The University of Pitesti, Targul din Vale Street no. 1, Pitesti, România*

⁴*Technical Sciences Academy of Romania ASTR, Dacia Avenue no.26, Bucharest, Romania*

⁵*The Academy of Romanian Scientists AOSR, Splaiul Independentei Street no. 54, Bucharest, Romania*

Abstract. Innovative design incorporates radical conceptual changes in design approaches or system configuration in comparison with existing practice and would, therefore, require substantial R&D, feasibility tests and a prototype or demonstration plant to be implemented. According to the classification currently used by the IAEA, small reactors are the reactors with an equivalent electric power less than 300 MW. The NuScale Power Module (NPM) is a small, light-water-cooled pressurized-water reactor (PWR).

To approach the R&D activity in the field of SMR, one can use the knowledge and expertise held by researchers regarding large reactors CANDU PHWR.

The paper synthetically presents a CANDU Nuclear Power Plant and a NuScale reactor and a short presentation of steam generators used for the two types of reactors.

Also, the paper includes a description of the processes and structural materials for the CANDU steam generator and the identification of known processes or those for which intense research activity must be developed to fill the knowledge gaps for the NuScale steam generators. Finding the answers for these issues supposes inter and transdisciplinarity in engineering sciences and technologies. Only by working in research teams including chemists, physicists, engineers specializing in materials science, metallurgy, energy, electronics can be identified and put into practice the optimal solutions for the proper functioning of innovative reactors.

Keywords: CANDU, PHWR, SMR, NuScale, steam generator, structural materials.

*Correspondence address: dumitra.lucan@nuclear.ro

1. Introduction

CANDU Nuclear Power Plant. The basic operation of the CANDU design is similar to other nuclear reactors. Fission reactions in the reactor core heat pressurized water in a primary cooling loop. A heat exchanger, also known as a steam generator, transfers the heat to a secondary cooling loop, which powers a steam turbine with an electric generator attached to it. The exhaust steam from the turbines is then cooled, condensed and returned as feedwater to the steam generator, Fig.1, [1]. Most commercial reactor designs use normal water as the moderator. Water absorbs some of the neutrons, enough that it is not possible to keep the reaction going in natural uranium. CANDU replaces this "light" water with heavy water. Heavy water's extra neutron decreases its ability to absorb excess neutrons, resulting in a better neutron economy. This allows CANDU to run on unenriched natural uranium. This was a major goal of the CANDU design; by operating on natural uranium the cost of enrichment is removed [1].

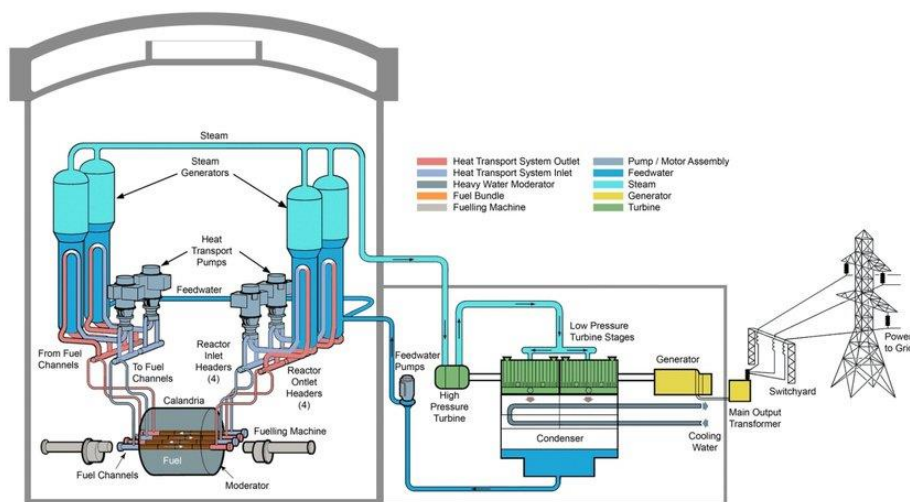

Fig. 1. Schematic presentation of a CANDU Nuclear Power Plant.

NuScale. The land-based water-cooled SMRs contains water-cooled SMR designs from various configurations of light water reactor (LWR) and heavy water reactor (HWR) technologies for on-land on-the-grid applications. These designs represent the mature technology considering most of the large power plants in operation today are of water-cooled reactors. There are twenty-five water-cooled SMR designs from 12 States that comprises integral-PWRs, compact-PWRs, loop-PWRs, BWRs, CANDU-type designs, and pool-type reactors for district heating.

Main design features for NuScale. According to the classification currently used by the IAEA, small reactors are the reactors with an equivalent electric power less

than 300 MW, medium sized reactors are the reactors with an equivalent electric power between 300 and 700 MW [2].

The NuScale Power Module™ (NPM) is a small, light-water-cooled pressurized-water reactor (PWR). The NuScale plant is scalable and can be built to accommodate a varying number of NPMs to meet customer's energy demands. The 60 MW(e) NPM provides power in increments that can be scaled to 720 MW(e) gross in a single facility with twelve modules. A twelve-module configuration is the reference plant size for design and licensing activities. Each NPM is a self-contained module that operates independently of the other modules in a multi-module configuration. NuScale design is a modular reactor for electricity production and non-electrical process heat applications.

The basic configuration of a single NuScale reactor module is shown schematically in figure 2 [3].

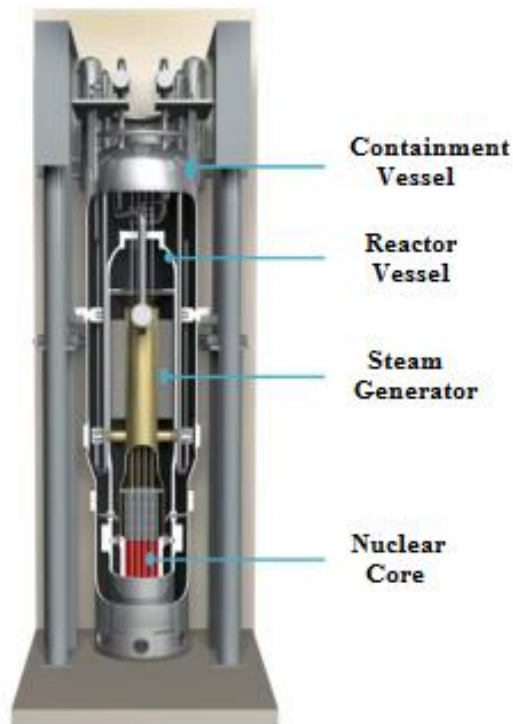

Fig. 2. NuScale Module.

The integrated nuclear reactor pressure vessel contains the nuclear core, a helical coil steam generator, and a pressurizer. It is approximately 20.0 m long by 2.8 m in diameter. The nuclear core consists of an array of reduced height LWR fuel assemblies and control rod clusters at standard enrichments. The helical coil steam generator consists of two independent sets of tube bundles with separate feedwater inlet and steam outlet lines.

Feedwater is pumped into the tubes where it boils to generate superheated steam. A set of pressurizer heaters is located in the upper head of the vessel to provide pressure control. The entire Nuclear Steam Supply System (NSSS) is enclosed in a steel containment that is 24.6 m long by 4.6 m in diameter. There are five essential features of the NuScale plant, which in combination, distinguish it from the many other small nuclear plants being developed today. The first is its *compact size*.

The NSSS can be entirely prefabricated off site and shipped by rail, truck or barge. At this size, it can be fabricated by mid-size domestic suppliers, avoiding the international choke point for forgings for conventional large plants.

Second, the nuclear *core is cooled entirely by natural circulation*. Water is heated in the nuclear core to produce a low density fluid that travels upward through the hot leg riser. The helical coils wrapped around the outside of the riser provide a heat sink that cools the water, causing its density to increase. The density difference acting over an elevation difference results in a buoyancy force that drives the fluid flow around the loop. Natural circulation operation provides a significant advantage in that it eliminates pumps, pipes, and valves and hence the maintenance and potential failures associated with those components. It also reduces in-house plant loads. This added simplicity enhances overall plant safety. Third, *the design relies on well-established light water reactor technology*. The NuScale plant can be licensed within the existing LWR regulatory framework, drawing on a vast body of established R&D, proven codes and methods, and existing regulatory standards.

Fourth, the *NuScale design is supported by a one-third scale*, electrically heated integral test facility which operates at full pressure and temperature. Operation of an integral test facility for such a non-conventional design is highly useful in seeking regulatory approval from governing bodies such as the U.S. Nuclear Regulatory Commission (NRC). Customers will also want assurance from integral facility tests that the plant will perform as predicted. This prototype test facility will provide the necessary supporting data required for licensing.

Finally, the *NuScale design is the only SMR that utilizes a compact movable modular containment*, in contrast to a traditional cast in-place concrete design. Similar to the reactor vessel, the use of a compact containment that is prefabricated off site and shipped by rail, truck or barge, enhances the economics and deployment flexibility.

This unique set of features, specifically the synergy created by plant simplicity, reliance on existing light water technology, and the availability of an integral test facility, all combine to position the NuScale plant for early deployment.

The NuScale plant design adopts design simplification, proven light-water reactor technology, modular nuclear steam supply system, factory-fabricated power modules, and passive safety systems that allow for unlimited coping time after a design basis accident without power, operator action, or makeup water. The NPM is designed to operate efficiently at full-power conditions using natural circulation as mean of providing core coolant flow, eliminating the need for reactor coolant pumps [3-5].

2. Steam generators for CANDU NPP and NuScale innovative reactor

CANDU Steam generator. This equipment is of the vertical recirculating type built by Babcock & Wilcox Canada Ltd. The CANDU 6 model contains 4 SGs per unit, Incoloy 800 tubing and SS-410 grid tube support and anti-vibrations bars (AVB). The primary coolant enters SG at 310 – 315⁰C and leaves at 270 - 280⁰C on the cold leg side [6]. Composition for Incoloy 800 is the next: C<0.02, Ni=30-35, Cr=19-23, Mn<1.5, Si<1, Cu<0.75, Ti=0.15-0.6, Fe=Bal.

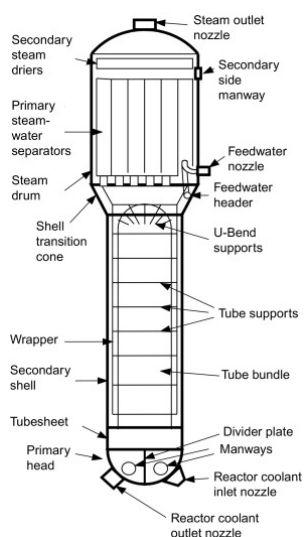

Fig. 3. CANDU Steam Generator.

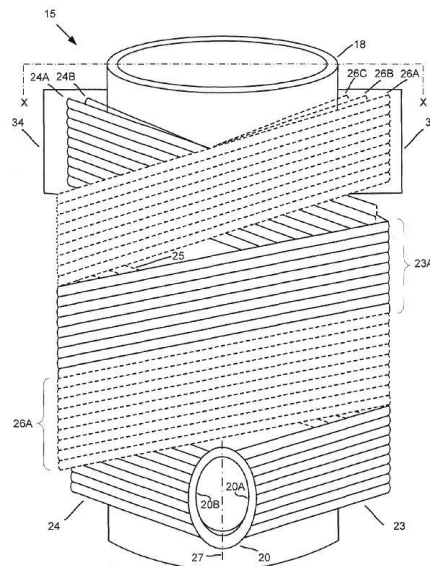

Fig. 4. Helical Coil Heat Exchanger.

NuScale Steam Generator NuScale employs a once-through, vertical helical coil steam generator design. With this design, feedwater enters into a lower integrated tubesheet plenum (ITP), flows upward through the tube bundle where it is converted to steam that exits through the upper ITP. One significant difference from a standard once-through design is that the secondary fluid (feedwater/steam) flows through the inside diameter (ID) of the tubes and primary water flows on the outside diameter (OD) [7].

The Romanian school was preoccupied with the sizing and operation of different types of heat exchangers, including the helical ones from the beginning of the researches in the field of chemical engineering, an example in this sense being the work of professor Emilian Bratu, [8].

Figure 4 is an illustration of flowpaths for the helical coil design provided for the purpose of general illustration only. In this illustration, the center element (18) is the riser. The riser is described as a structure that functions as a hot leg, directing core outlet flow upward through the center region of the vessel where the core flow

is directed radially outward, then downward through the steam generator section. The lower integrated tubesheet / plenum (ITP) directs feedwater flow through into the tube bundles (at 20A & 20B). The tube bundles represented by items 23 & 24 carry fluid to the upper ITP. Current plans include two independent tube bundles. Feedwater 5-27 and steam flows may be independently controlled to the independent bundles to allow for continued operation in the event of a failure of a tube in one of the steam generator bundles.

NuScale indicates that tubes will be hydraulically expanded into the tubesheet, although the specific details of this design do not appear to be finalized. The tubesheet connection is likely to be significantly thinner than prior designs and would need either to be clad with an austenitic material such as Alloy 52 or constructed from an Alloy 690 plate or forging. In addition, evaluation remains in progress to determine if connecting welds can be seal welds only or if the welds must have a structural function. Regardless of the specific configuration, the tube to tubesheet design configuration will be different in some respects from traditional tube to tubesheet connections. If a low-alloy tubesheet is used, then the tubesheet must be clad on the tube side, since primary water containing boric acid flows on the OD of the tubes. If the tubesheets are fabricated from Alloy 690 plate or forgings, this will be a relatively new application of Alloy 690 in a LWR. An additional configuration detail of note is the need to install flow orifices at in the tube inlets for the purpose of precluding density wave flow oscillations within the tubes. These orifices must be removable to facilitate inspection from the inlet end of the tubes.

Notably, the risk of PWSCC within the steam generator should be somewhat reduced in comparison with large advanced PWRs. Operating temperatures associated with the NuScale design are lower; hot leg temperature for the NuScale design is approximately 310°C, compared with hot leg temperatures at or above 315.5°C for all Gen. II and advanced PWR designs. Additionally, the large radius of curvature of the helical coil reduces the potential for high fabrication-induced stresses, as can occur at recirculating steam generator U-bends. However, it has not yet been determined if the helical coil bends will be heat treated after forming. Consequently, the amount of cold strain in the thermally treated Alloy 690 tubes will need to be considered relative to existing data on PWSCC growth rates in cold worked material.

Given the relatively large radius of the coils, this is not expected to be a concern. The major concern of alloy 690 SCC in secondary water due to concentrated impurities (lead in particular) should also be reduced since line-contact crevices are eliminated on the tube ID. There have been some issues in advanced gas-cooled reactor steam generators where secondary water is boiled into steam and superheated on the tube ID with a tendency for fouling and concentration of impurities in the boiling crisis zone. It is important to note that the NuScale steam generator is expected to operate quite differently. More detailed analysis is recommended for the SCC potential in the alloy 690 tubing as the steam generator design evolves further.

Composition for alloy 690 is the next: C=0.05, Fe=7-11, Cr=27-31, Mn<0.5, Mo=8-10, Si<0.5, P<0.015, Cu<0.05, Ni=Bal.

Materials of construction for the tube supports have not yet been finalized, but will likely be Type 405 stainless steel. Selection of materials for this application introduces a significant new application of ferritic stainless steel as a passive, long-lived structure within the primary system. Type 405 stainless steel has been used extensively in secondary-side tube support applications, but not in the primary system. Although the application does not raise any significant degradation concerns, some investigation to ensure no vulnerabilities exist seems reasonable.

To summarize the steam generator evaluation, no specific materials performance concerns were identified. However, the NuScale steam generator design differs significantly from the recirculating or straight tube once-through designs used for PWRs. As a result, research focused on mitigating SCC risk in large advanced PWRs will not be relevant to the NuScale design. There may also be unique considerations associated with the tube-to-tubesheet connections. Additional materials R&D with a focus on the NuScale design specifics would be needed to demonstrate long-term performance [9; 10].

3. R&D on the corrosion behaviour of the CANDU steam generator materials

The operation and maintenance of steam generator is one of the most crucial and complex elements in the success of pressurized water reactor operations. For many nuclear utilities steam generator remain the leading cause of plant outage hours, high maintenance costs and reduced generating capacity. As a result, more and more utilities are faced with reality that steam generators will not endure the life of the plant, and will require either expensive repairs or complete replacement. Therefore, the effective management of steam generators requires more than solving the problems as they arise, it requires anticipation of issues so that effective planning can be performed in advance. A steam generator strategy must specify a balance between the objectives of reducing short and long term capital and operation and maintenance budgets with the risk of unscheduled or extended outage and reduced plant availability factor. In the purpose to extend steam generator life most of the remedial measures taken must to address operational effects on steam generator degradation. Maintenance activities intended to extend steam generator life and reduce the potential for costly forced shutdowns must to be implemented at the Nuclear Power Plants. A comprehensive inspection program is able to detect problems at an early stage so that necessary actions can be implemented. The Steam Generator tubing degradation caused by corrosion and other age-related mechanisms continues to be a significant safety and cost concern for many Steam Generators. Understanding Steam Generator ageing mechanisms is the key to effective management of Steam Generator ageing and consists of knowledge of Steam Generator materials and materials properties, stressors and operating conditions, likely degradation sites and wear mechanisms. The paper

presents the principal types of corrosion which can occur in CANDU Steam Generator.

There are also presented the operation conditions, the specifications referring to the water chemistry and the construction materials of Steam Generator, the factors which have a great influence on the corrosion behaviour during the whole exploitation period of this equipment. Also the paper presents the most important methods which have like principal objective the mitigation of the degradation processes specific for the CANDU Steam Generator.

The steam generators (SG), equipments that ensure the connection between the primary and the secondary circuits, create several safety problems during operation, mainly due to corrosion and mechanical damages. Maintenance is also difficult in the SG because of the limited access to various components and because of the presence of the high radiation field existing on the side of the primary circuit.

For manufacturing the SG several types of steels are used, whose coexistence in the environmental conditions of the steam generator arises special problems with respect to corrosion. Corrosion and the mechanical damage in the SG are the result of complex interaction between chemistry, adequate thermo-hydraulic design, selection of generator construction materials, utilisation of compatible materials for the entire secondary circuit, conditions of achieving equipments and facilities and the operation technique, Fig. 5.

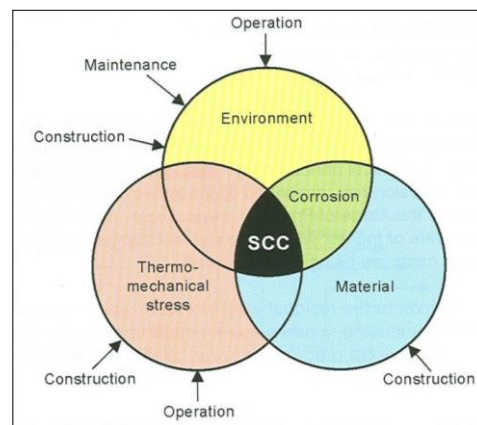

Fig. 5. Factors affecting steam generator's corrosion various factors: strict control of water.

This is why a careful analysis of corrosion problems is required, necessary both from an economic point of view and for the safe operation.

The most important element in selecting the SG construction materials is their resistance to corrosion in special operation conditions.

Incoloy-800 is utilised for pipes for the following reasons: presents good resistance to stress corrosion cracking , as compared to Inconel- 600, releases a much smaller

amount of radioactive products in the primary circuit, has a high resistance to cracking corrosion in alkaline environment (20% higher than Inconel-600). The SG includes the following types of steels: Incoloy-800 (tubes), Inconel-600 (tubesheet), stainless steel SA 240-410 S (intermediate supports), carbon steel SA 516-gr. 70 (shell), carbon steel SA 508 cl.2 (support plate).

The chemical control of water is done by the maintaining of the parameters between certain limits that influence the corrosion behaviour of SG materials: the amount and composition of corrosion products, impurities (dissolved salts) and oxidation agents.

Although the corrosion products are not directly responsible for corrosion, they are the main cause of the accumulation and concentration of aggressive species that can lead to a variety of corrosion forms. The corrosion products will be carried from the SG in the entire system, determining the occurrence of corrosion-related inconveniences, even and in areas where apparently this would not be possible. The main source of penetration of oxygen and impurities is coolant leakage from the condenser. The impurities concentration is responsible for the initiation, propagation and acceleration of corrosion processes in the SG tubing. This is why it is compulsory a careful control of water chemistry, of reactants addition and of the cleaning degree after maintenance or repairs.

Types of corrosion specific to the steam generator. Degradations due to corrosion can be divided into two large groups: degradations that end up in cracking and those which do not imply cracking. Corrosive degradations produced in the absence of a significant stress (applied, residual or due to corrosion products deposition) will not end up in cracking, except for certain cases such as intergranular corrosion.

Corrosion that does not imply cracking can appear itself under the following three specific forms: generalised corrosion and localised corrosion (pitting, crevice corrosion etc).

Generalized corrosion. It has been proven that stainless steels and nickel-rich alloys present in the SG undertake a generalized corrosion; their corrosion rates vary in time approximately parabolically. The corrosion products release rates decrease in time, following various kinetics. Generalized corrosion prevails in the case of carbon steels.

Since most of the studies were performed in static autoclaves, particular care is required if one desires the extrapolation of results for typical conditions in nuclear facilities, where the influence of the thermal transfer and of coolant circulation is added, due to thermo-hydraulic parameters.

The corrosion mechanism of these materials consists in the formation of two overlapped layers of compounds, the outer one being crystalline. Based on this model, it was assumed that the total rate of the film formation is controlled by the migration rate of iron species soluble in water through the pores of the oxide layer: part of the oxidized iron is included in the magnetite formed in the area of contact with the metallic under-layer (forming thus the inner film), while the remaining is carried into the solution, at the outer edge of the oxide layer where it can

precipitate, forming the crystalline outer film, or its release can occur in the solution mass, precipitating at random. The corrosion products entailed in the working fluid will deposit in the restricted circulation regions, thus contributing to the initiation of corrosion in those areas.

Localized corrosion. This type of corrosion supposes the fast local dissolving on a significant depth and it can induce destruction of the base material.

Localized corrosion is an extremely dangerous phenomenon, since it usually takes place in less aggressive environments - where generalized corrosion is negligible - and it is quite difficult to be detected, due to its location and very small dimensions.

Denting corrosion. If the cooling water was phosphate-treated and then treated with volatile amines (AVT) one noticed the occurrence of a corrosive attack called denting. This means the deformation of Incoloy-800 tubing due to the increase in volume of corrosion products formed between the intermediary carbon steel support plate and the Incoloy-800 tube.

Around each Incoloy-800 tube that penetrates the intermediary support plate there is a gap of a few tenths of a millimetre. Within this space an accelerated corrosion of carbon steel was noticed, resulting in magnetite. Magnetite accumulates in time and exerts a compression force on the tube; this one can distort, leading to a local striction in the tube, called dent.

This denting corrosion can also lead to the blocking of the sondes used in eddy-current examinations of the tubular bundle.

Consequently, denting is a form of corrosion in the crevice between the tube and the support plate, where an initial concentration of acid species (chlorides, sulphates) takes place.

The oxygen, copper and nickel ions act as accelerators of denting. The occurrence of this event can be avoided by choosing appropriate construction solutions for the intermediate supports, utilization of stainless steel for these supports, treatment, from the very beginning, with volatile amines and removal of copper from the composition of the secondary circuit equipments.

Corrosion under the impurities layer (wastage). Another type of corrosion likely to occur when treating water with phosphates is the "wastage" corrosion. This one takes place under the deposits on the tube surface, in the areas where wet and dry periods alternate.

It is known that during SG operation a sludge accumulates on the tubesheet, reaching a height of 30 cm or more. As the sludge content increases, the coolant cannot reach the surface in order to replace the evaporated liquid. The temperature in this region becomes equal to that of the coolant. The area where the strongest corrosion is encountered is the interface, where wetting and drying alternate, which determines the thinning of the Incoloy-800 tube. Using adequate constructive solutions can diminish the phenomenon.

Pitting corrosion. Pitting corrosion can appear both on the Incoloy-800 tubing and on the tubesheet. Thus, pits with a depth of 0.02-0.05 mm have been observed on the Incoloy-800 tubes in the crevices where denting occurred, determined by a high

concentration of chlorides. Pitting was also observed on the tubesheet, especially under the sludge.

Stress corrosion cracking. This type of corrosion was more frequently identified on the U-shaped upper region of Incoloy-800 tubes, but cracks have been noticed in other areas, too. The cracks that appeared in the U-bend region has been generally initiated from the inside of the tube. The examination of such tubes shown that these cracks initiated on the side of the primary agent are of intergranular nature, oriented along the longitudinal axis of the tube.

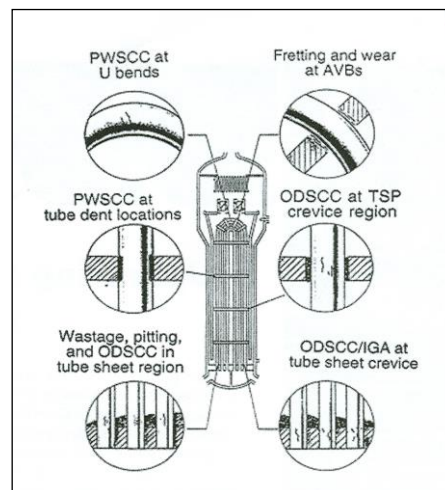

Fig. 6. Types of corrosion specific to SG.

Mechanical degradations of the SG tubing. The degradation of steam generator components increase current operating costs significantly and could force the premature shutdown of some plants before the end of their initial 40 year license term. Even for plants that can operate until the end of their current license period, material degradation issues will strongly affect license renewal decisions. Steam generator replacements are expensive, on the order of \$150 million plus the cost of replacement power. Mechanical degradations that may alter SG tubing can be divided into: vibrations wear (fretting) and fatigue wear. These degradations belong to the category of localized attack. The strength that determines them is produced by tubes vibration, induced by flow circulation. This time, corrosion appears as an additional factor that accelerates mechanical degradation of the tubes; it acts synergistically. The effect of the synergetic action of the two factors varies from the erosion of passive films on the materials surface to the accelerating effects of certain aggressive environments on the quality of the metal. In the case of cracks initiated on defects (for example in regions where local thinning of tubing walls took place) a transgranular attack was identified on the tubes outer surface. The mechanism of these cracks includes the fatigue fretting corrosion in the presence of corrosive species in the environment.

Fig. 2 is a schematic layout of corrosive attacks specific to the CANDU Steam Generators. The most important types of corrosion are: primary and secondary stress corrosion cracking, crevice, intergranular, pitting and wastage corrosion on the secondary side of the steam generator [11; 12].

Research is needed to understand, characterize, and manage service induced degradation of steam generator components. Technology development needs to be focused on timely detection, mitigation, and prevention of significant long-term effects of aging such as stress corrosion cracking and structure degradation. A research program to address environmental degradation of steam generator structures would be a multi-year program involving laboratory tests [13 - 16].

The objectives of the program concerning the steam generator are the follows: identifies the relevant ageing degradation mechanisms and discusses the issues associated with continued safe and economic operation of that key equipment, summarizes the current research and development activities and identifies the research needs in the future. Figure 7 shows the principals experimental research concerning the degradations of the CANDU steam generator.

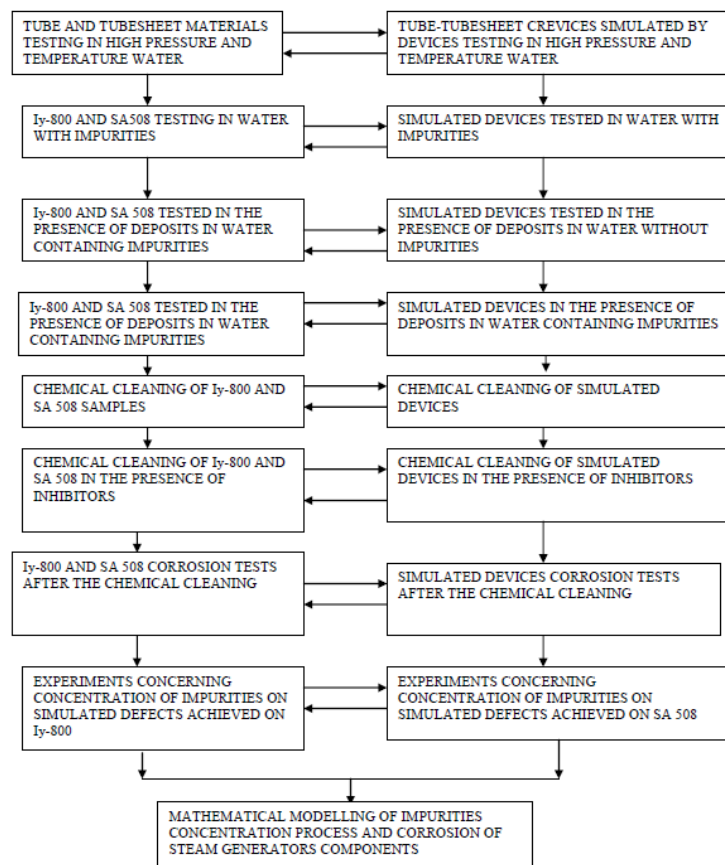

Fig. 7. Experimental research.

The experimental results obtained and the expertise gained during the development of this research activity can be used in the purpose to assess the types of degradations for NuScale structural materials.

4. Conclusions

The occurrence of corrosion in the steam generators creates problems of economic nature, safety in operation and prediction of the operation period of components after damage.

The factors that influence the corrosion behaviour of steam generators' structural materials during operation and after maintenance are presented under the form of corrosion types susceptible to appear. Among them the most dangerous is the localized corrosion with its specific patterns: SCC, denting, wastage, pitting, intergranular etc.

The experimental results obtained for the CANDU steam generator consist in the correlation between the nature of materials used for the construction of various components of the steam generator, the chemical characteristics of the circulating environment and the way in which certain of their abnormalities can lead to the occurrence of different types of corrosion.

The paper states that the knowledge obtained based on experience gained in the field of structural materials degradation by research activity from large pressurized reactors can be applied to small modular reactors.

References

- [1] Pioro I., Duffey R.B., Kirillov P.L., *Current status and future developments in nuclear power industry of the world*, ASME J. of Nuclear Rad. Sci., **5**, 2, 2019.
- [2] ***, *Status of small reactor designs without onsite refuelling*, IAEA TECDOC-1536, IAEA, Vienna, 2007.
- [3] <https://www.nrc.gov/reactors/new-reactors/smr/nuscale.html>
- [4] Sandusky D., Lunceford W., *Assessment of materials issues for light-water small modular reactors*, Pacific Northwest National Laboratory, PNNL-22290, 2013.
- [5] Reyes J. N., *NuScale plant safety in response to extreme events*, Nucl Tech, **128**, 2012, p. 153-163.
- [6] Riznic J., *Steam generators for nuclear power plants*, Science Direct, 2017.
- [7] Williams D. K., Fasset, D. P., *Helical coil steam generator*, United States Patent US no. 9188328B2, Nov. 17, 2015.
- [8] Bratu Em., *Calculation of spiral heat exchangers*, Politechnic Institute Bucharest, Communications session, 1958.
- [9] Jianling D., Yu X., Jiyang F., *Study on steam generator helical tube integrity assessment of HTR*, 20th International Conference on Structural Mechanics in Reactor Technology, Espoo, Finland, August 9-14, 2009.
- [10] Hoffer N. V., Sabharwall P., Anderson, N.A., *Modelling a helical-coil steam generator in RELAP5- 3D for the next generation nuclear plant*, Idaho National Laboratory, INL/EXT-10-1962, 2011.
- [11] Lucan D., Valeca S. C., Jinescu Ghe., Mihalache M., *Romania's contribution to the development of the knowledge society in the field of nuclear energy research*, Journal of Engineering Sciences and Innovation, **4**, 4, 2019, p. 399-410.

- [12] Lucan D., Valeca S. C., Jinescu G., *Plant life extension programs - useful resources for preservation and amplification of nuclear power plants efficiency*, Journal of Engineering Sciences and Innovation, **5**, 4, 2020, p. 329 – 338.
- [13] Lucan D., Jinescu Ghe., *Corrosion analysis and diagnosis - usefull tools for plant life management and long term operation programmes in nuclear power plant*, Journal of Engineering Sciences and Innovation, **2**, 3, 2017, p. 80-92.
- [14] Lucan D., Jinescu Ghe., Dinu A., Stanciulescu M., Mihalache M., *CANDU steam generator secondary side fouling characteristics*, Journal of Engineering Sciences and Innovation, **4**, 1, 2019, p. 31 – 42.
- [15] Lucan D., *Behavior of the steam generator tubing in water with different pH values*, Nuclear Engineering and Design, **241**, 4, 2011. p. 1172-1176.
- [16] Lucan D., *CANDU steam generator corrosion due to the impurities of concentration and deposition, capitol in steam generators: Design, Types and Applications* (Book), Editor: Clayson Schellenberg, Nova Science Publishing, New York, Series: Energy Science, Engineering and Technology, 2017, p. 197-226.