



Technical Sciences
Academy of Romania
www.jesi.astr.ro

Journal of Engineering Sciences and Innovation

Volume 2, Issue 4 / 2017, pp. 11-19

*A. Mechanics, Mechanical and Industrial Engineering,
Mechatronics*

Received 14 June 2017

Accepted 4 October 2017

Received in revised form 27 September 2017

Mechanical simulator of the CANDU fuelling machine

SERBAN VALECA^{*1}, CONSTANTIN IORGA², MONICA VALECA³

¹*University of Pitesti, Romania, and corresponding member of the Romanian Academy*

²*Institute for Nuclear Research, Pitesti, Romania*

³*University of Pitesti, Romania*

Abstract: Fuelling Machines (F/Ms) in CANDU type reactors are high accuracy robots that operate in maximum safety and reliability conditions. The paper describes the independent equipment Mechanical Simulator (MS) of F/M designed and performed as original variant at Institute for Nuclear Research (INR) from Pitesti. MS is dedicated to develop commissioning activities - checking and functional tests, adjustments, settings – of the F/M(s) test rig, for effective testing of them. Together with the other F/M simulators, MS constitutes the basic structure for periodic training of the test rig operators.

Keywords: mechanical simulator, fuelling machine, injection.

1. Introduction

Fuel Handling (F/H) system of a CANDU reactor consist of equipment that provide transfer of the fresh nuclear fuel to the F/M, its entering in the reactor core and transfer of the spent fuel discharged from reactor into the cooling pool and hence to store, [1]. The main components of F/H are the F/M(s); one at each face of the reactor is tandem operating for refuelling. During one of machines is fuelling the fresh fuel into reactor the other one is receiving the spent fuel from the same fuel channel. The refuelling is performed with the reactor in service.

During operation, the F/M(s) (Fig. 1) are pressure vessels and a part of the Primary Heat Transport System of the reactor, that handling the nuclear fuel into the reactor core.

*Correspondence address: serban.valeca@nuclear.ro

Considering the working conditions and complexity of operations performed, the F/M(s) are the high accuracy machines, with special reliability, that provides the operation of entire CANDU system in safety and maximum efficiency conditions. Before to be installed in the nuclear power plant, the F/M(s) are subjected to complex checking, adjusting and testing operations in order to demonstrate their performances and reliability.

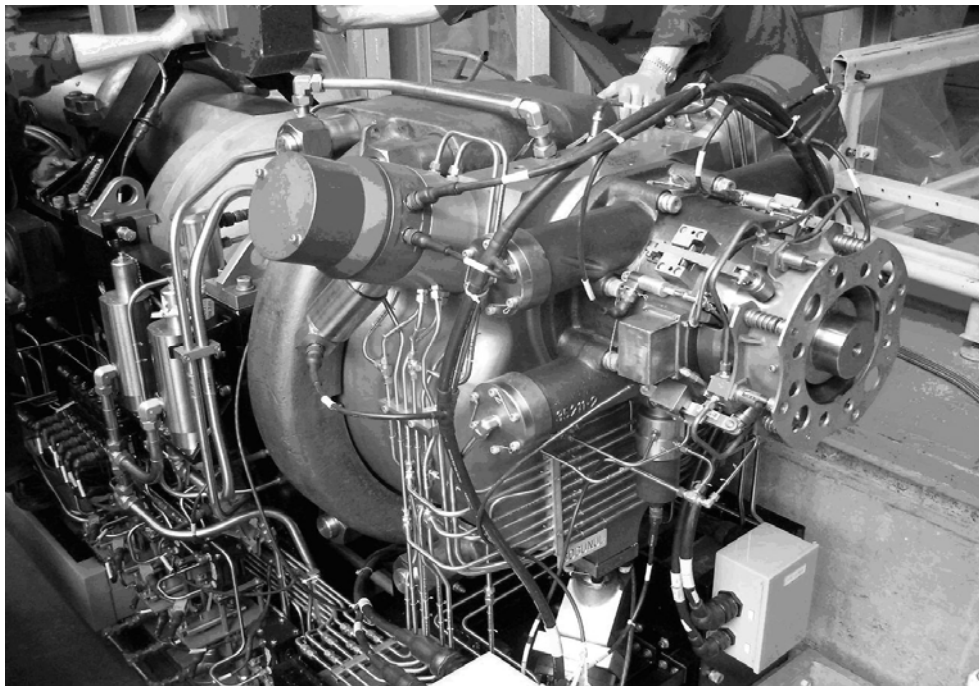

Fig. 1. Frontal view of Fuelling Machine.

To achieve this goal, at INR Pitesti has build a special F/M(s) test rig for CANDU reactors. By its structure and designation, it is unique in Europe, the AECL Canada having a similar installation.

At INR has successfully performed, as a national and European premiere, the CANDU F/M(s) testing for Cernavoda NPP Unit 2. Previously, the operating personnel and the test rig has licensed by AECL Canada representatives. The licensing activities have performed using the MS - one F/M tested missing. The activities have performed in Quality Management System complying with ISO 9001: 2000 for research, testing, design, fabrication activities of nuclear equipment and nuclear plant operation. The Quality Management System has licensed by Lloyd's Register Quality Assurance and authorized by the National Commission for Nuclear Control Activities (CNCAN).

2. F/M test rig

The F/M test rig from INR Pitesti (Fig. 2) has performed by a Romanian design and is entirely complying with testing requirements of AECL – Canada. The installations and equipment assembly of the test rig and the afferent control and checking systems are similar to those from CANDU reactor, and perform the identical operating parameters (temperature, pressure and flow rate) to those from reactor to actuate the F/M for refuelling in nuclear fuel channel, [2].

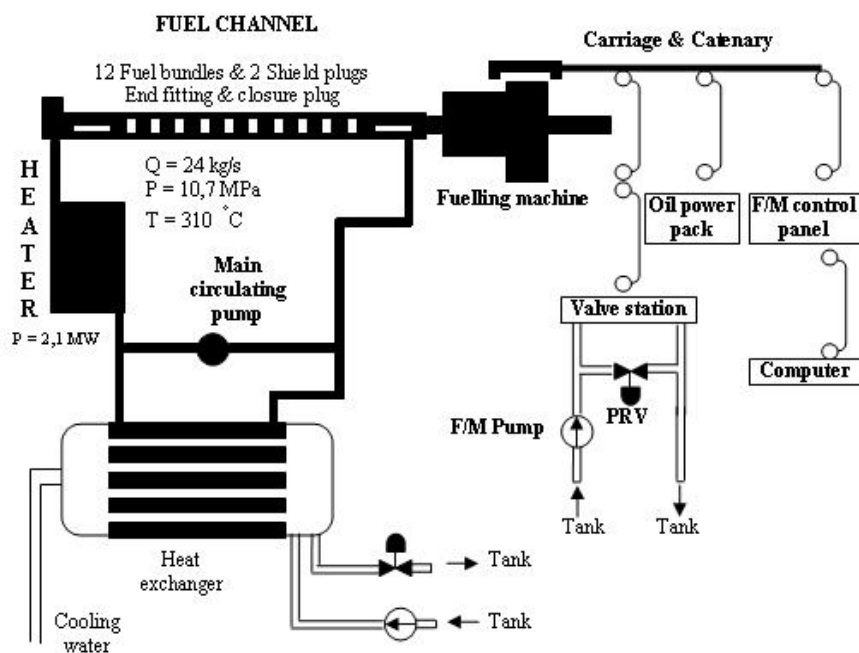

Fig. 2. Flow chart of the F/M(s) test rig.

The main component parts of the rig are: the thermo-hydraulic hot and cold loops, the PHWR type fuel channels, oil groups, valve station, catenaria, F/H carriage assembly. The entire operational testing process of the F/M(s) is monitoring by the control panel and process computer placed in the Control Room.

3. Simulators of the CANDU F/M test rig

To license the F/M(s) test rig from INR Pitesti, the AECL – Canada representatives proposed using of a F/M already tested to prove the functionality and the performances of the rig. Taking into account the difficulties and implications that could be generated by this solution and unavailability of a tested F/M, the INR

specialists proposed an alternative solution agreed by the parts involved. Thus, have designed and executed two independent equipment – mechanical simulator and electrical simulator (ES) of the F/M- which takes the function of a machine, and generates feed-backs required for checking the thermo-hydraulically performances of the rig in testing conditions, of the operation logic of electric control and checking components, as well as the computer soft for automatic testing-control.

The simulators have used for making ready the test rig (checks, settings and adjustments of the mechanical and electrical equipment) before testing of each F/Ms, too.

4. The F/M mechanical simulator

During the pre-acceptance and acceptance operational tests, when the F/M is connected to the fuel channel, into the channel is injected a flow rate of 1.5 kg/s, with a 20 – 90°C temperature and a pressure of 11,8 MPa.

This injection is required in the real operation condition in reactor so that the fluid to flow only from F/M to the nuclear fuel channel. Thus is cutting off the possibility to contaminate the F/M head (snout clamp assembly, the magazine assembly and B, C rams and latch Z ram) with heavy water from primary heat transport system of the reactor, and is preventing production of some thermal shock to the F/M head components, [3].

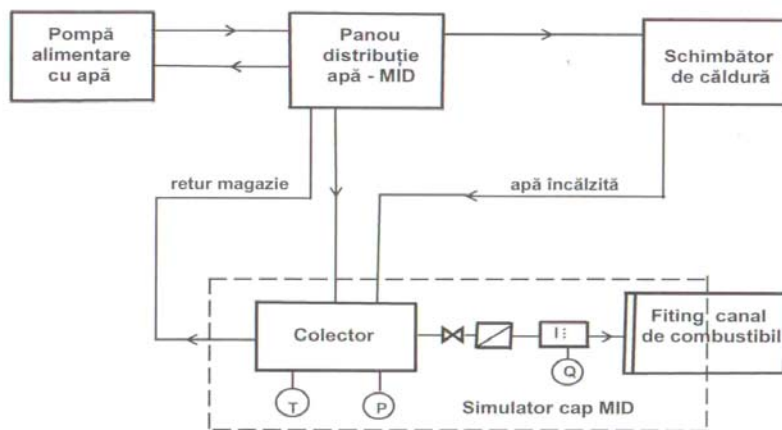

Fig. 3. Mechanical simulator connected to the test rig equipment.

The F/M mechanical simulator has designed as a pressure vessel with simulation role of the F/M magazine. This provides the interface between the valve station and

hot/cold loop of the test rig. The interface with test rig is performed at the fuel channel level (Fig. 3) providing the injection into the channel.

The field transducers of simulator have been connected to the automation available circuits of the test rig afferent to F/M magazine; auxiliary, for local monitoring of parameters, provided the pressure and flow rate monitoring instruments placed in the field, [4].

Checks, settings and functional tests of the mechanical and automatization equipment of the F/M test rig are performing before testing of each F/M. After these activities have completed MS is disconnected from the valve station, fuel channel respectively and remakes the initial structure of the test rig.

The MS (Fig. 4) had a determined role to prove the capacity of the test rig for keeping its thermal stability and performing the working parameters during injection regime.

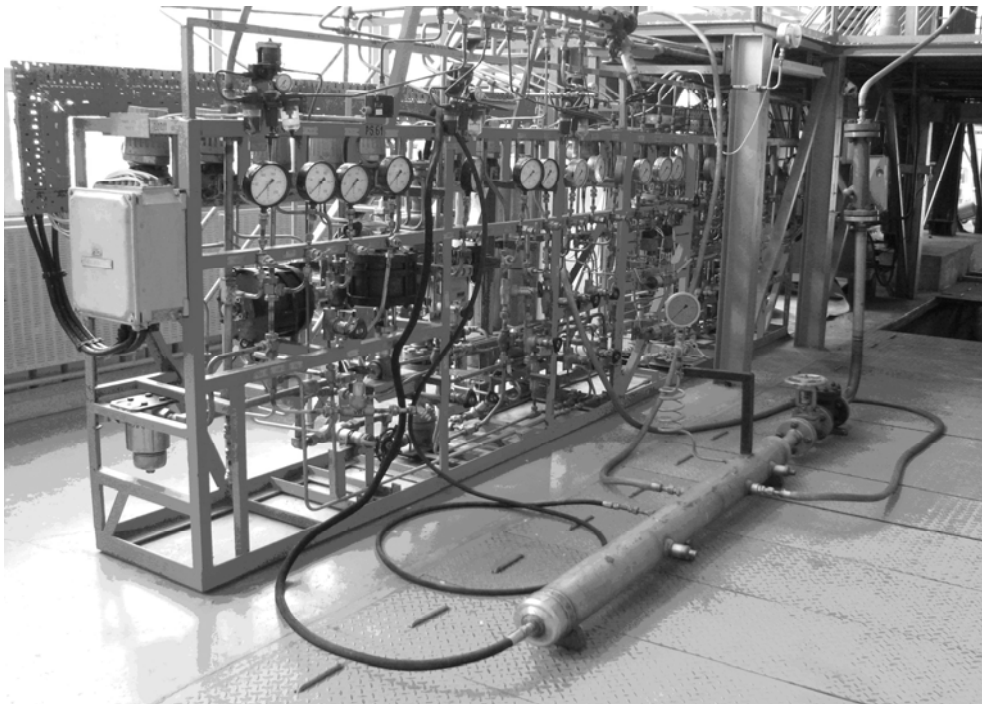

Fig. 4. F/M mechanical simulator connected to the valve station.

The functional test final stage of the test rig using MS performed in the presence of the AECL Canada representatives; on this occasion demonstrated:

- the rig capability to perform and maintain the pressure difference between the fuel channel of the test rig and the MS (Fig. 5); the close control of the pressure in hot loop.
- the possibility to maintain simultaneously the hot loop and valve station parameters, on and during injection time; we mention that the two installation have

different supply sources and functions before injection, they having interface only when the F/M is connected to the channel.

- well behaviour of the supply pipes, of the fuel channels and of the feeders (self-balanced lines) at sudden contraction generated by the injection process.
- the stability of the physical chemical parameters of the working fluid (water chemical treated with: pH = 9.5 - 10.5, maximum O₂ dissolved = 200 ppb/kg, maximum conductivity = 2 mS/cm³), taking into accounts the mixture between the cold (20°C - 90°C) and hot (310°C) water.

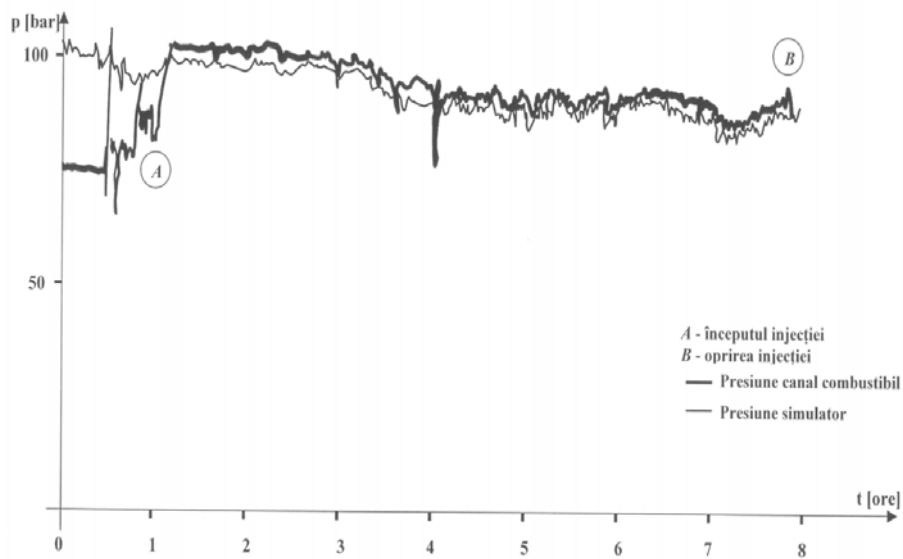

Fig. 5. Water pressure in the fuel channel and in the Mechanical Simulator.

- demonstration of the thermal stability (Fig. 6) of the hot loop in operation transitory regime (injection) using the modernized high power electric heater. Demonstration performed complying the heating rate of the water during transitory regimes (maximum 0.8°C/min.), with working limit range imposed by the saturation pressure characteristic of the water dependent on temperature (Fig 7). At first stage of test using MS set off under-sizing of the electrical heater for heating of the working fluid. Based on the test results, its power has improved from 1680 KW to 2100 KW providing a spare power about 5% of requisite to.

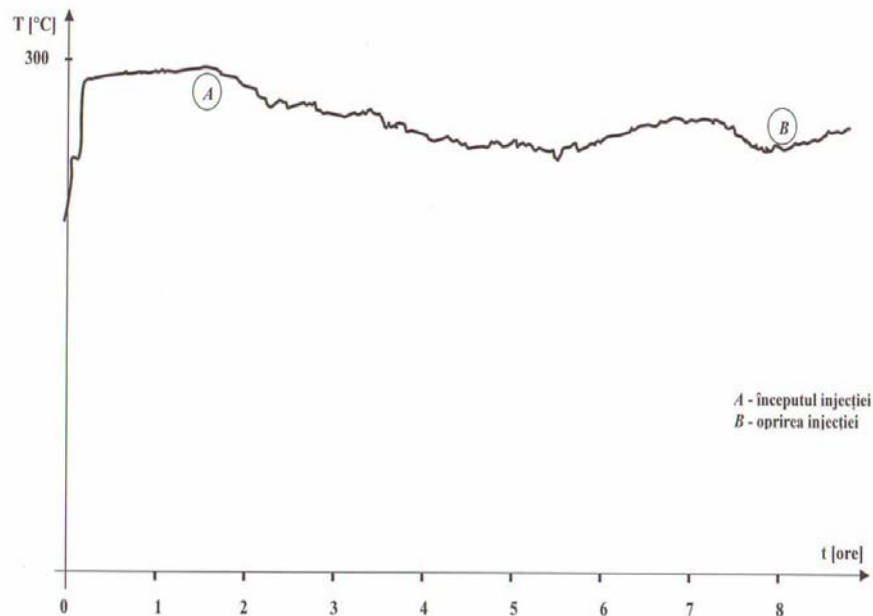

Fig. 6. Water temperature variation from hot loop during injection.

- capability of the thermo-hydraulic systems of the test rig (five section heat exchanger, buffer tanks, ADD tank and corresponding monitoring and control equipment) to cool the hot – cold water mixture until about 60 °C;
- capability of the feed-bleed systems to blow-down the additional water volume introduced by injection (range C-D from Fig. 8 diagram), so that the flow rate of the hot loop main line to remain constant;
- capability to maintain the water level in the buffer – tanks during injection;
- performances of the electric monitoring and control systems to manage the feedbacks received from installation field during injection test executed with MS, [5].

The licensing tests of F/M test rig using MS has conducted according to Job R6 – a special program which is using for testing the F/M. During the entire test, temperature, pressure and flow conditions has maintained between imposed limits. The resulting data submitted for the test demonstrates that the F/M test rig from Pitesti is capable of providing the thermo-hydraulic parameters to meet the requirements of the F/M test procedures.

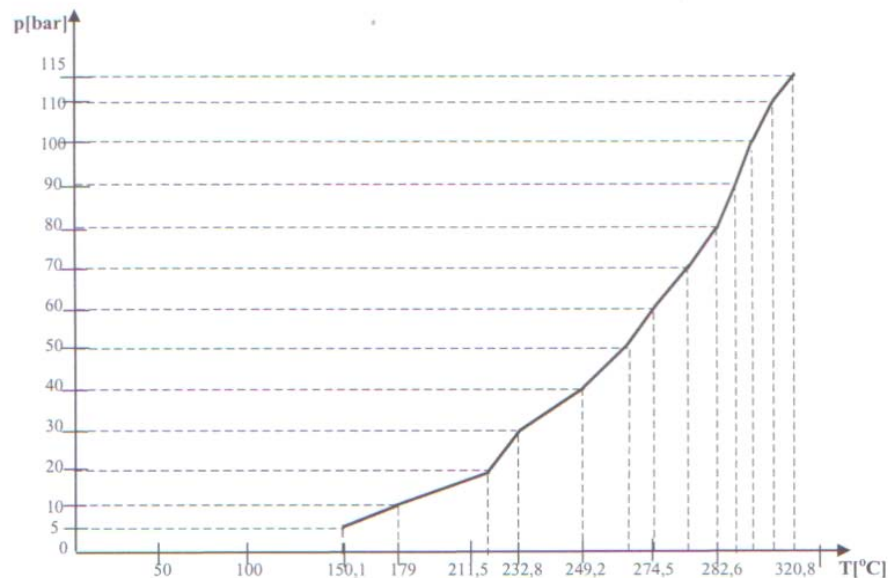

Fig. 7. Water saturation pressure depending on temperature.

In the last years, both simulator (MS and ES) and test rig have subjected to some modernizing works, to comply with recently requests of potential CANDU power plant owners, interested in testing facilities of F/M from INR Pitesti.

5. Conclusions

Over the last 39 years the Institute for Nuclear Research developed technologies, methods, computer codes, its own experimental infrastructure, directed towards an end product or service with applications in a nuclear power plant.

The Institute is involved in nuclear power development and continues to act as technical support for the safe and economical operation of the NPP.

During the last decade, the research activity of the Institute was oriented with priority towards applied and engineering research, within programs with objectives connected to present and future specific issues of CANDU NPP; testing of Fuelling Machine for Cernavoda NPP Unit 2 at INR Pitesti is an example to that.

Out of Reactor Department from INR Pitesti have the staff, the experience and the facilities to perform new cooperation activities with CANDU reactor owners for testing of F/H components, analysis and interpretation of experimental data, training, a.i.

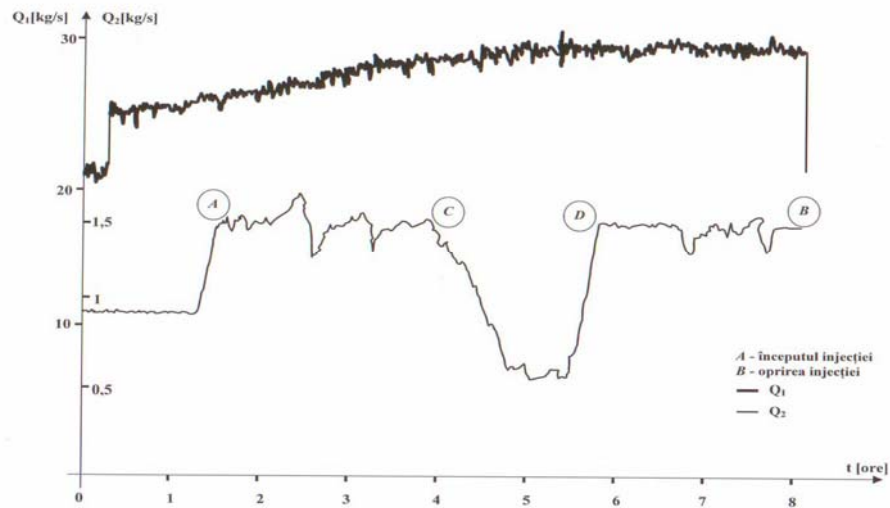

Fig. 8. Q1 – hot loop flow rate; Q2 – injection flow rate.

References

- [1] C. Bratianu, et al., *Nuclear power strategies and channels*, Technical Publishing House, Bucuresti, 1990
- [2] P. Fecteau and M. Wilson, *Assessment of Hot Channel Test with Simulated F/M Flow Injection from INR Pitesti*, AECL - Canada, Report #08.707-020129-0001-02, April 2002
- [3] S. Valeca, et al., *Cold water injection test in the channel with F/M mechanical simulator using cold loop from INR Pitesti*. Internal Report no. 3450, INR Pitesti, 1991
- [4] N. Marinescu, et al., *Appliance of the measurement – setting temperature loop for the water injection test using simulator*, Internal Report no. 3327, INR Pitesti, 1991.
- [5] S. Valeca, et al., *Cold water injection water tests in the channel with F/M mechanical simulator using hot loop*, Internal Report no. 3451, INR Pitesti, 1991.